

# "WHHRM300DC and WHHR400DC"



**Whole House Heat Recovery Unit with Low Energy  
DC Motor - for domestic and commercial use**

**Installation, Operating and Maintenance  
Instructions**



Vectaire Ltd, Lincoln Road, Cressex Business Park, High Wycombe, Buckinghamshire, HP12 3RH  
Tel: +44 (0)1494 522333. Fax: +44 (0)1494 522337. Email: [sales@vectaire.co.uk](mailto:sales@vectaire.co.uk)

## Table of contents

	Chapter	Page
<b>Application</b>	<b>1</b>	<b>1</b>
<b>Version</b>	<b>2</b>	<b>2</b>
Duct connection options	2.1	2
Bypass	2.2	2
Technical information	2.3	3
Fan graphs	2.4	4
<b>Design</b>	<b>3</b>	<b>5</b>
Exploded view appliance	3.1	5
Component functions	3.2	5
<b>Operation</b>	<b>4</b>	<b>6</b>
Outline description	4.1	6
LED indication system and control panel	4.2	6
Bypass conditions	4.3	6
Frost protection	4.4	7
Filter indication	4.5	7
Option pcb	4.6	7
<b>Installation</b>	<b>5</b>	<b>8</b>
Installation general	5.1	8
Siting the appliance	5.2	8
Connecting ducts	5.3	8
Connecting the condensate discharge	5.4	9
Electric connections	5.5	10
Connecting the multiple switch	5.5.1	10
Connecting the OpenTherm connector	5.5.2	11
Connecting the power	5.5.3	11
Connections / dimensions Vectaire WHHRs	5.6	12
Connections / dimensions type WHHRM300DC	5.6.1	12
Connections / dimensions type WHHR400DC	5.6.2	13
<b>Operation instructions</b>	<b>6</b>	<b>14</b>
Switching the appliance on and off	6.1	14
Setting the air quantity	6.2	14
Other user settings	6.3	15
Installer settings	6.4	16
Menu structure display	6.5	17
Diagram menu structure	6.5.1	17
Readout settings	6.6	18
Readout settings by the user	6.6.1	18
Readout settings by the installer	6.6.2	18
Modifying settings	6.7	19
Modifying settings by the user	6.7.1	19
Modifying settings by the installer	6.7.2	19
Adjustable settings table	6.7.3	20
<b>Fault</b>	<b>7</b>	<b>21</b>
Trouble shooting	7.1	21
Filter fouled indication	7.2	21
Display codes	7.3	21

## Table of contents

	Chapter	Page
<b>Maintenance</b>	<b>8</b>	<b>22</b>
User maintenance	8.1	22
Installer maintenance	8.1	23
<b>Electric diagrams</b>	<b>9</b>	<b>25</b>
Basic diagram without bypass	9.1	25
Basic diagram with bypass	9.2	26
Wiring diagram without bypass	9.3	27
Wiring diagram with bypass	9.4	28
Wiring diagram connection preheater to WHHRM300DC & 400DC without option pcb	9.5	29
<b>Service</b>	<b>10</b>	<b>30</b>
Exploded view Vectaire WHHRM300DC and WHHR400DC	10.1	30
Replacement/ spare parts	10.2	30
Appendixes		31
Declaration of conformity		31



These appliances are very economic Vectaire heat recovery units with an efficiency of up to 95% and energy-saving constant-volume fans. The new generation stands out for its:

- steplessly adjustable air flow rates through a control panel;
- filter indication on the appliance and the possibility for filter indication on the multiple switch;
- completely new frost protection system that ensures optimum performance of the appliance, even at very low atmospheric temperatures;
- noise reduction due to limited pressure fluctuation.

The appliance comes ready for use. All control equipment has been mounted and checked in the factory.

On installation, the appliance must be connected to the air ducts, the condensate discharge, the mains supply and the multiple switch.

The installer can change the desired air flow for every setting with the aid of the control panel on the appliance. See Chapter 6 for a detailed description.

The possibilities of these WHHRs can be extended by using the separately available option pcb that the installer can place in the appliance. For a description of the possibilities of the option pcb, see section 4.6 and wiring diagram section 9.4.

This option pcb is described in more detail in the installation instructions that come with the option pcb.

It is possible to connect a preheater to the basic pcb of the WHHRDCs without having to install an option pcb (see section 9.5).

The WHHRDCs are available in two versions as regards ventilation capacity:

- “WHHRM300DC” has a ventilation capacity of up to 300 m<sup>3</sup>/h at 150 Pa resistance in the duct system;
- “WHHR400DC” produces a maximum of 400 m<sup>3</sup>/h at 150 Pa resistance in the duct system.

Both versions are available with or without a bypass unit. They are ready to be hard wired to the mains and a connection for the low-voltage multiple switch on the outside of the appliance.

### 2.1 Ducts connection options

The WHHRDCs are available in three versions as regards ducts connections:

- all connections at the top; type 4/0 as standard
- “to dwelling” at the bottom; type 3/1
- “to dwelling” and “from dwelling” at the bottom; type 2/2

For pictures and dimensions of these appliances, see sections 5.6.1 & 5.6.2.

### 2.2 Bypass

The appliance can be supplied ex factory with a bypass, which can be used to interrupt the heat recovery if desired, to supply fresh, cool outside air. The information and diagram in these installation instructions refer to the bypass that is supplied ex factory; in this version the heat exchanger is equipped with a sliding grate that shuts off the supply air through the exchanger.

When a bypass has been retrofitted, it is no longer possible to mount a sliding grate.

The operation and preconditions of the bypass control are explained in more detail in section 4.3. The bypass unit that is retrofitted to the appliance has the same control system as the factory-fitted bypass.

## 2.3 Technical information

		WHHRM300DC			WHHR400DC		
Supply voltage [V~/Hz]		230/50					
Protection degree		IP31					
Dimensions (w x h x d) [mm]		675 x 602 x 420			675 x 602 x 430		
Duct diameter [mm]		Ø150			Ø180		
External diameter condensate discharge [mm]		Ø20					
Weight [kg] (Excl. bypass unit of 3.5 kg)		31			32		
Filter class		G3 (F6 optional)					
Fan setting		1	2	3	1	2	3
Ventilation capacity [m <sup>3</sup> /h respectively] - Factory settings		100	150	225	100	200	300
Permissible resistance in the ducting [Pa]		15 - 31	31 - 66	64 - 138	8 - 17	31 - 59	67 - 128
Rated power [W]		18 - 20	32 - 38	70 - 90	20 - 21	53 - 60	121 - 149
Rated current [A]		0.13 - 0.14	0.22 - 0.26	0.49 - 0.59	0.2	0.42 - 0.60	0.9 - 1.09
Cos φ		0.60 - 0.61	0.62 - 0.63	0.63 - 0.66	0.54	0.61 - 0.62	0.61 - 0.62
Noise capacity level L <sub>w</sub> (A)	Static pressure [Pa]	40	80	160	40	80	240
	Housing emission [dB(A)]	28.5	38	46.5	<32	42	52.5
	Duct "from dwelling" [dB(A)]	<24	33	41	<30.5	38	46.5
	Duct "to dwelling"	48.5	56	66	51.5	61.5	69

		Bypass unit					
Supply voltage [V/Hz]		230/50					
Protection degree		IP31					
Dimensions (w x h x d) [mm]		675 x 602 x 85					
Weight [ kg]		3.5					
Rated power [W]		5					
Rated current [A]		0.02					

2.5 Fan graphs

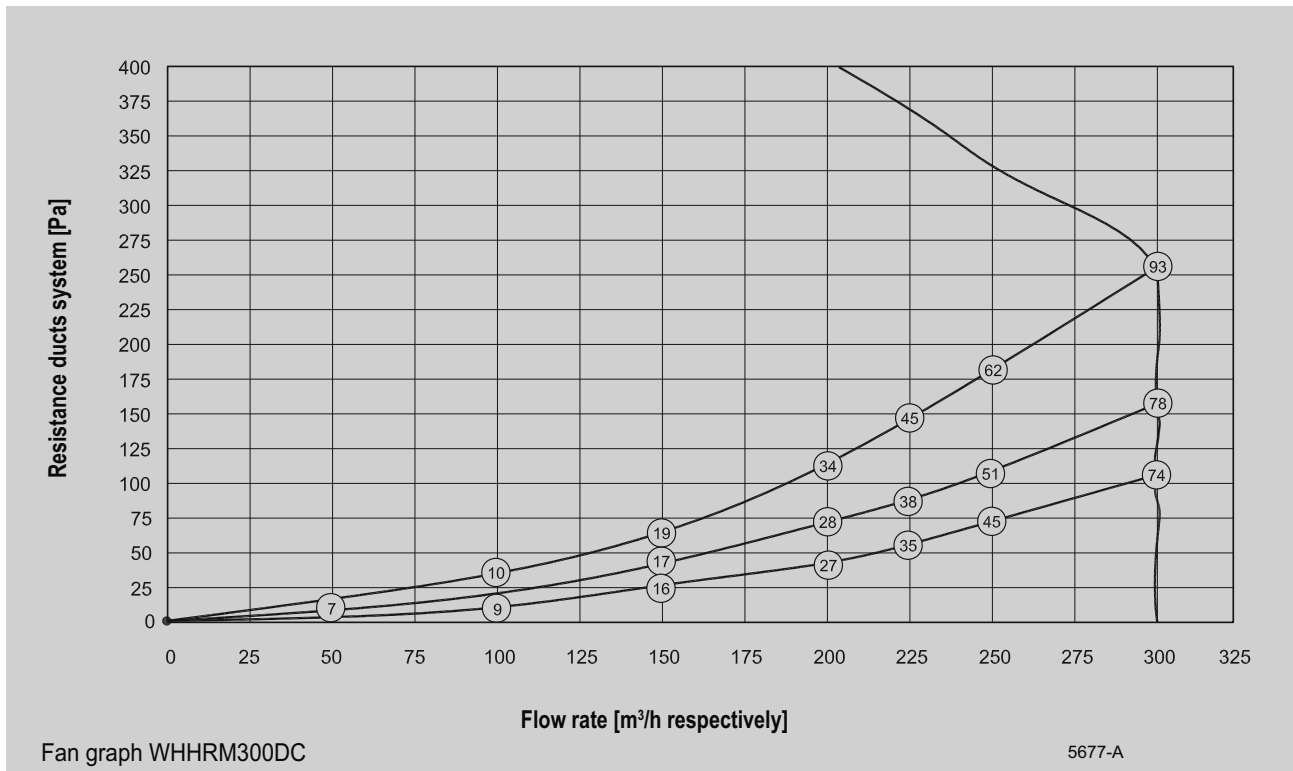

Note: The value stated in the circle is the capacity per fan (in Watts)

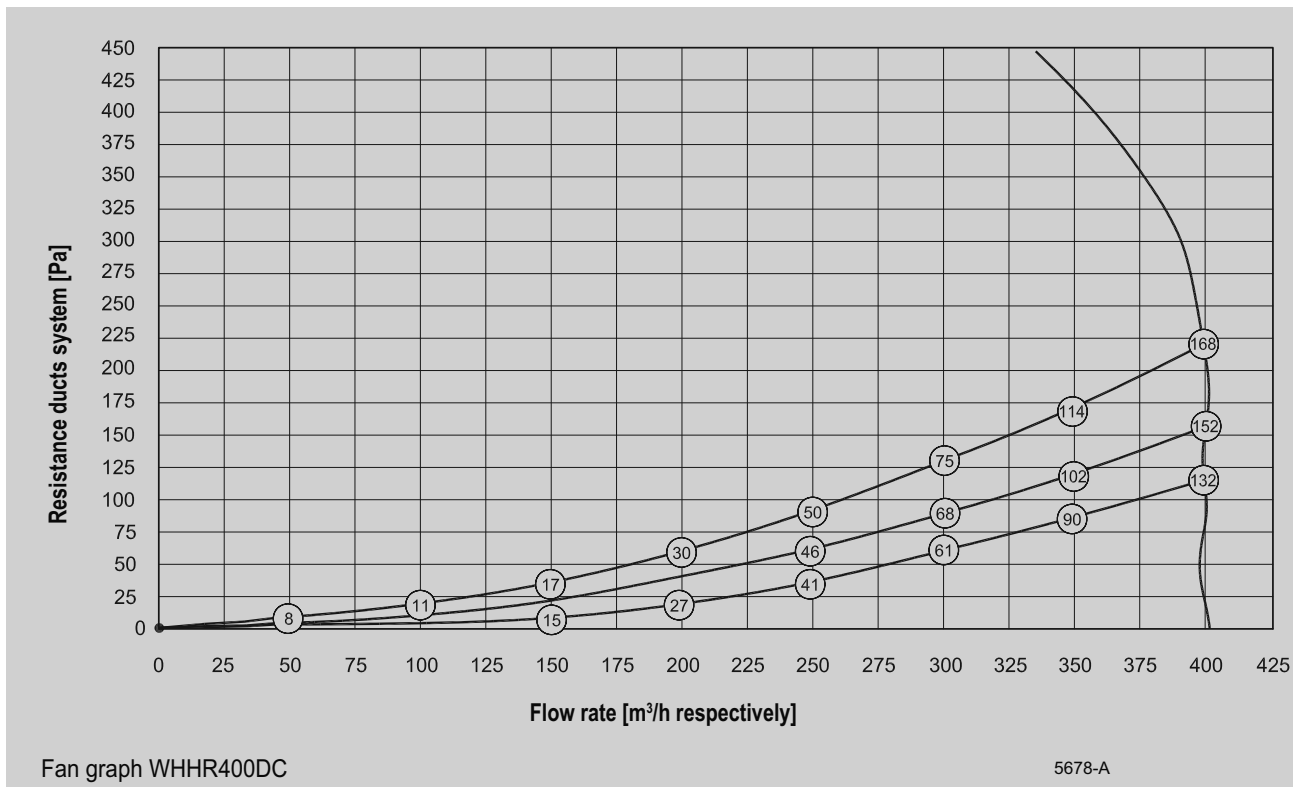

Note: The value stated in the circle is the capacity per fan (in Watts)

3.1 Exploded view appliance

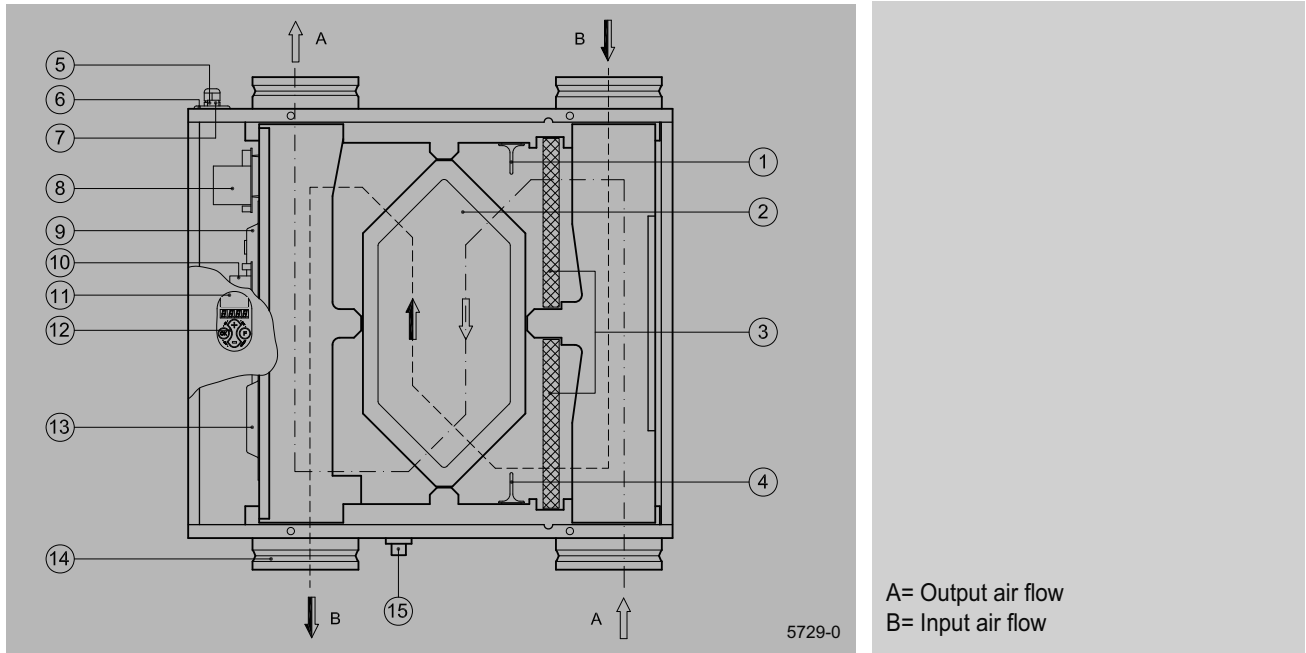

3.2 Component functions

1	Interior temperature sensor	Measures the temperature of the air from the dwelling.
2	Heat exchanger	Ensures heat transfer between input and output air
3	Filters	Filter both air flows.
4	Atmospheric temperature sensor	Measures outside air temperature.
5	Communication port	Connections for cable to multiple switch, if desired with filter indicator.
6	Cable grommet	Grommet for feeding through power cable 230 Volt
7	OpenTherm connection	Two-pole connector for OpenTherm control
8	Option pcb (non-standard)	Contains various additional control inputs and outputs for provisions such as a pre-heater, a postheater, two control valves, CO <sub>2</sub> sensor, H <sub>2</sub> O sensor and emergency setting.
9	Input fan	Feeds fresh air into the dwelling.
10	Basic pcb	Contains the control electronics for the basic functions.
11	Computer port	Computer connection for service purposes.
12	Control panel	Interface between user and control electronics.
13	Output fan	Discharges fouled air from the dwelling to the atmosphere.
14	Duct spigots	Connections for the input and output ducts.
15	Connection condensate discharge	Connection condensate discharge.

#### 4.1 Outline description

These appliances are highly advanced heat recovery units, specially designed for minimum energy consumption and maximum comfort. This is achieved with the aid of various electronic control systems. A control unit with microprocessor controls and monitors the safe operation of the appliance and ensures that the air quantities remain constant

and at the preset values.

The units come with a control panel with display, enabling stepless adjustment of the volume without having to open the appliance. Moreover, information regarding the operation can be read out from the outside of the appliance.

#### 4.2 LED display system and control panel

The Vectaire appliances are fitted with a control panel. It can be used to retrieve and modify the settings in the control unit program.

The control panel has four keys and a display.

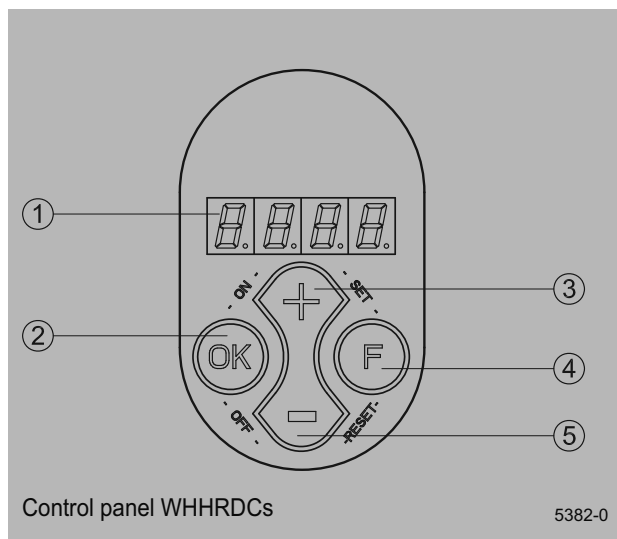

- 1 = Display
- 2 = Key "OK" (confirm, ready, filter indication reset)
- 3 = Key increase parameter
- 4 = Function key
- 5 = Key decrease parameter

On the left the display indicates the ventilation setting or the parameter type. On the right it shows the readout value, for instance the preset air flow.

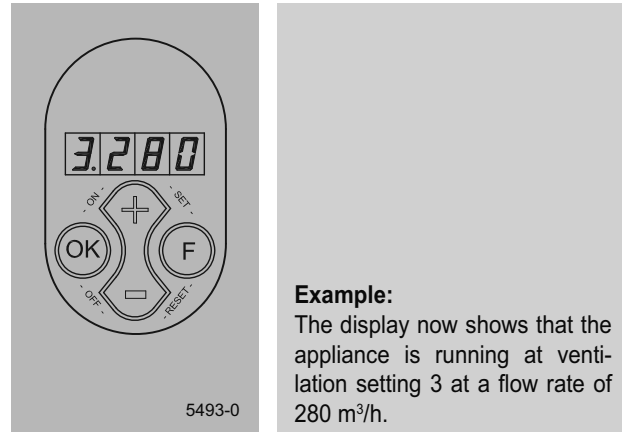

#### Example:

The display now shows that the appliance is running at ventilation setting 3 at a flow rate of 280 m<sup>3</sup>/h.

The 4 keys have the following functions:

- F Function key / switching on and off parameter menu
- + Next parameter / increase value
- - Previous parameter / decrease value
- OK Switching on and off settings menu / manual fault reset/ filter indication reset

Other commands can be entered with key combinations.

- F & + (set), confirm parameter value
- F & - (reset), parameter value back to factory setting
- OK & + (ON), switch on appliance
- OK & - (OFF), switch off appliance

Wherever this booklet states that a key has to be pressed, the key in question is printed in quotation marks and in bold.

Example: - press key "**OK**".

#### 4.3 Bypass conditions

The bypass, if mounted, makes it possible to supply fresh outside air that is not heated by the heat exchanger. Particularly during summer nights it is desirable to supply cooler outside air. Then the hot air in the dwelling is replaced by cooler outside air so far as is possible. The bypass damper opens when the interior temperature exceeds an adjustable temperature (standard

22 °C) while the outside air is warmer than an adjustable temperature (standard 10 °C) but colder than the interior air. Outside air supplied through the bypass is still being filtered, so the air quality is optimal, irrespective of the bypass setting.

The installer can set the bypass for different situations at adjustable parameter I8 (also see §6.4).

#### 4.4 Frost safety

The frost protection system ensures that the secondary side of the heat exchanger (outlet side) does not freeze up by introducing an imbalance between the inlet and outlet air flows,

dependent on the outside air temperature and the pressure across the heat exchanger.

---

#### 4.5 Filter indication

The appliance is fitted with a filter indication system. It indicates on the display when the filter is fouled. For more detailed information refer to sections 7.2 and 8.1.

---

#### 4.6 Option pcb

The Vectaire appliance can be equipped with an optional pcb (product code 289990). It provides the following functions.

##### Input 0-10 V for a carbon dioxide sensor

When several people are present in the dwelling, more CO<sub>2</sub> is produced and then this sensor automatically increases the ventilation quantity.

##### Input 0-10 V for a humidity sensor

When the humidity content in the dwelling increases, for instance when someone is taking a shower, this sensor automatically increases the ventilation quantity.

##### Switching input for bedroom valve.

With this input (make contact) the bedroom valve can be controlled, for example by using a time switch.

##### Switching output for bedroom valve 24 volt AC

The option pcb has a built-in control for a 24 volt AC bedroom valve. Such a valve can directly be connected to the pcb. The valve can be controlled from the switching input for the bedroom valve.

##### Control for preheater up to 1000 W

The preheater ensures that the input air is kept above 0°C, so the WHHRDCs can continue the balanced ventilation also at very low atmospheric temperatures. The option pcb contains a control for a preheater up to 1000 W. The preheater can be connected to the option pcb without separate control. The hook-up wire of the preheater must be fed into the appliance; the 230 V power cable must separately be connected to the option pcb.

##### Control for postheater up to 1000 W

The postheater ensures that the supply air that is blown into the dwelling can be kept at the preset temperature. That way additional warmth can be brought into the dwelling. The option pcb contains a control for a postheater up to 1000 W. The postheater can be connected to the option pcb without separate control. The hook-up wire of the postheater must be fed into the appliance; the 230 V power cable must separately be connected to the option pcb.

##### Two freely programmable input connections

These inputs make it possible :

- to open the bypass without regard for the temperature conditions;
- to switch the inlet or outlet low or high, to circumvent the frost protection;
- to switch the inlet low when the bypass opens.

##### Switch input for emergency.

A fire alarm can be connected to this input. As soon as the fire alarm is triggered, the appliance switches to emergency mode.

As standard this is set to switch off the fans.

### 5.1 Installation general

The appliance installation procedure can be summarised as follows:

1. Siting the appliance (§5.2)
2. Connecting the ducts (§5.3)
3. Connecting the condensate discharge (§5.4)
4. Electric connection:  
Connecting the multiple switch and, if necessary, the mains power and the OpenTherm connector (§5.5)

The WHHRDC must be installed in accordance with:

- Quality requirements ventilation systems dwellings,
- Quality requirements balanced ventilation in dwellings,
- The regulations for ventilation of dwellings and residential buildings
- The relevant electrical safety regulations,,
- The regulations for connection to interior sewers in dwellings and residential buildings,
- Any additional regulations of the local authorities
- The installation instructions for the WHHRDCs.

### 5.2 Siting the appliance

- The appliance can be wall or floor-mounted. A wall hanging bracket is supplied.
- Ensure the appliance is level when fitted.
- It should be in the warm part of the building. If fitted in the roof space above the normal level of insulation the insulation should be interrupted and fitted over and around the appliance forming an insulated compartment.
- It should be sited so that good condensate discharge with trap can be fitted.
- Ensure there is a free space of at least 700 mm at the front of the appliance to provide room for opening the door and a free headroom of 1.8m for maintenance purpose.
- To avoid noise disturbance do not fit above a bedroom and if in the roof space fit on an acoustic mat. If wall hung on a wall with a mass of less than 200kg/m<sup>2</sup> additional measures such as double panelling, extra studs or an acoustic mat will be required.
- If required a mounting support for floor mounting is available (product code 217031).

### 5.3 Connecting ducts

The air outlet does not have to be fitted with a control valve. The appliance itself controls the air volume.

To prevent condensation on the ducts to and from the outside, self-insulated ducting should be used. Alternatively use an insulated duct with a vapour barrier.

To limit fan noise use acoustic duct for a length of 1 metre immediately after the appliance on the ducts to and from the dwelling. Where any duct runs outside the insulated envelope they must be insulated. Design the duct runs so as to avoid noise transmission and "crosstalk" particularly with separate branches to the dampers.

The duct spigots of the Vectaire WHHRM300DC are fitted with sealing loose rings  $\varnothing 160$  mm. The duct spigots of the Vectaire WHHR400DC are fitted with eccentric adapters of  $\varnothing 180$  mm. The centre of the connecting duct can be shifted by rotating these eccentric adapters if space is restricted.

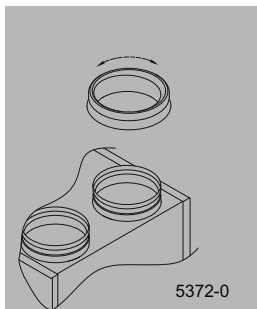

The maximum permissible resistance in the system is 150 Pa at the maximum ventilation capacity. If the resistance in the duct system is higher, the performance of the appliance will be adversely affected.

Always use Vectaire air supply and extract room valves to minimise resistance. Air supply valves should be sited so as to avoid direct draughts which cause discomfort to residents. To ensure air flow throughout there should be gaps under doors of 10 mm.

The exterior air supply should be on the sheltered or leeward side of the building and can be sited on the roof or wall. The exhaust air terminal should be sited on the roof well away from the air supply to avoid recirculation - at least 900 mm if on the same side of roof.

### 5.4 Connecting the condensate discharge

The condensate discharge line for the WHHRDCs is fed through the lower panel. The condensate must be discharged through a drainpipe. The drain must discharge under the water level in the U-trap. The condensate discharge comes separately in the packaging and the installer must screw it into the underside of the appliance. This condensate discharge connection has an external connecting diameter of 20 mm.

The condensate discharge line can be glued to it, if necessary using a 90° bend. The installer can glue the condensate discharge in the desired position in the lower part of the appliance.

See the drawing below for an example of a connection to a drainpipe. (Pour water into the bend to create an air trap, if connecting to a soil pipe - refer to local bye-laws ).

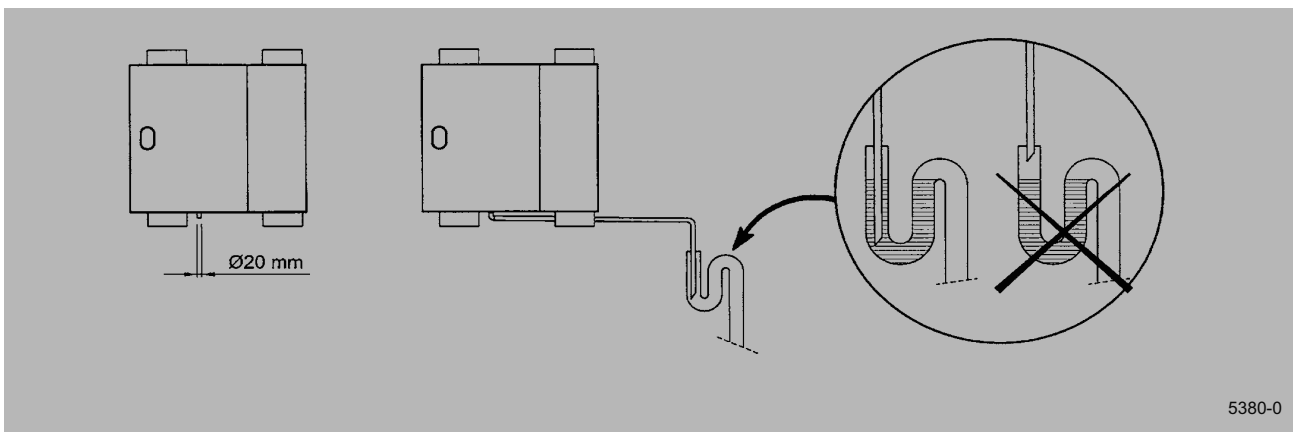

5380-0

**5.5 Electric connections**

The appliance comes ready to be wired into the mains

**5.5.1 Connecting the multiple switch**

The multiple switch (supplied as an extra) is connected to the modular connector type RJ12 that is placed at the top of the appliance. (See A figure below)

- Application of a 3-way switch with filter indication in all cases requires an RJ12 plug in combination with a 6-core modular cable.

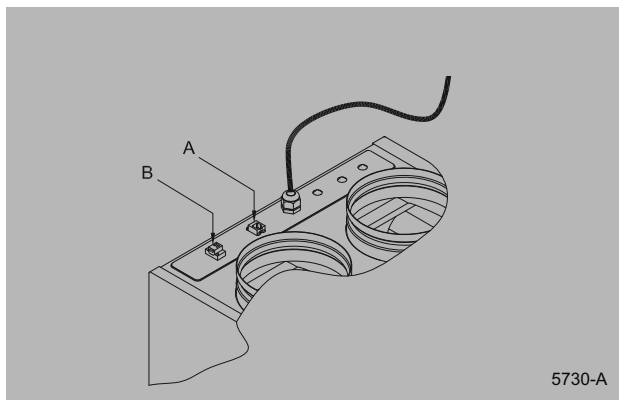

A = Modular connector  
B = OpenTherm connector

The figure below shows the method for connecting a 3-way switch, viz.:

- A. 3-way switch with filter indication; switch with modular connector (6-core cable, two modular connectors RJ12/6),

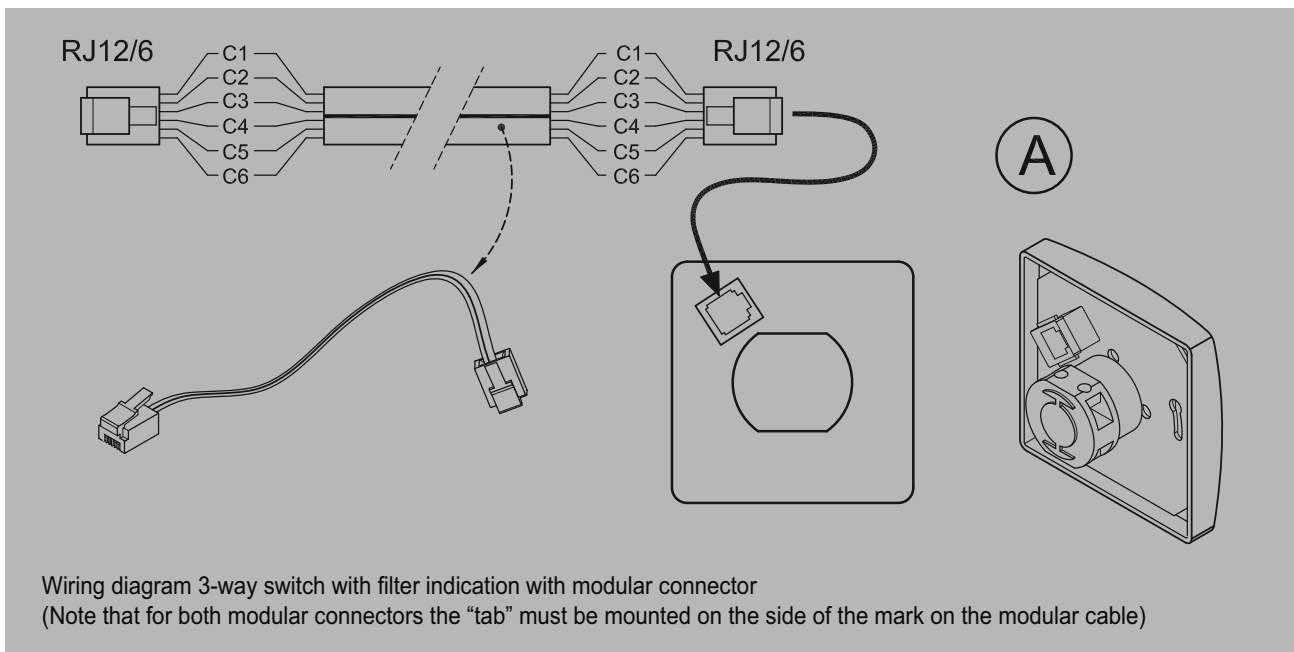

### 5.5.2 Connecting the OpenTherm connector

In combination with demand-controlled ventilation, the appliance can also be controlled with the OpenTherm protocol instead of a low-voltage switch. OpenTherm allows continuous adjustment of the rpm for the flow rate. A 2-core low-voltage

cable with a core diameter of at least 0.8 mm<sup>2</sup> must be used as connecting cable. Interchanging the cable connection to the 2-pole screw connector does not influence the appliance's performance.

---

### 5.5.3 Connecting the power

The appliance should be connected to the mains circuit by a qualified electrician. The electric installation must comply with the regulatory requirements.

**Warning**

The fans and controls carry a high voltage. Always disconnect from the mains when working on the appliance.

5.6 Connections and dimensions WHHRDCs

5.6.1 Connections WHHRM300DC

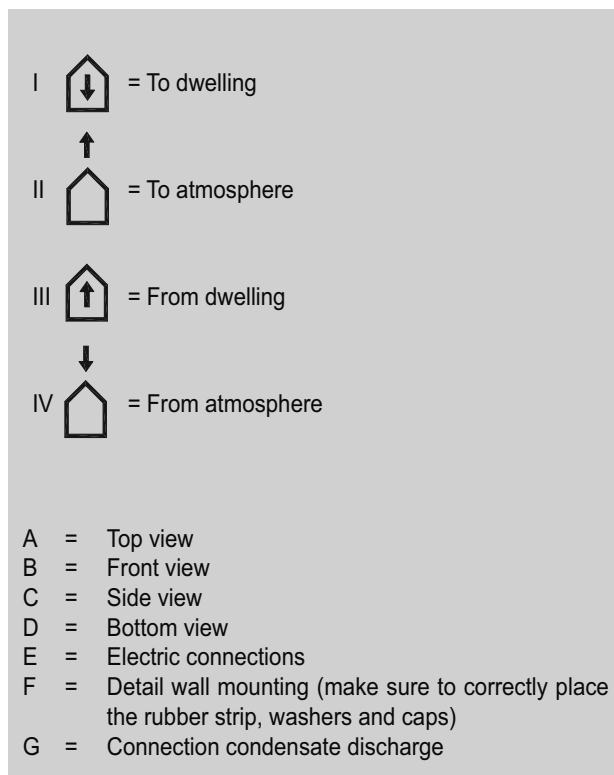
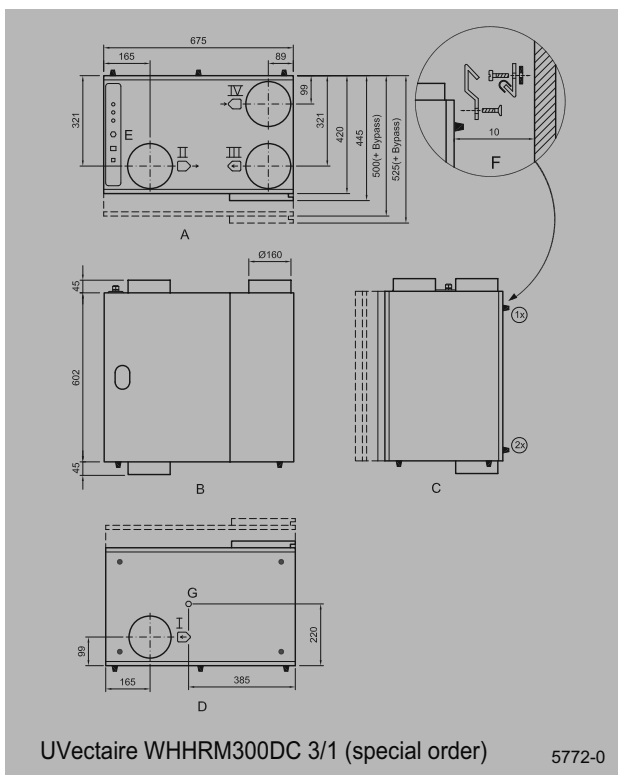
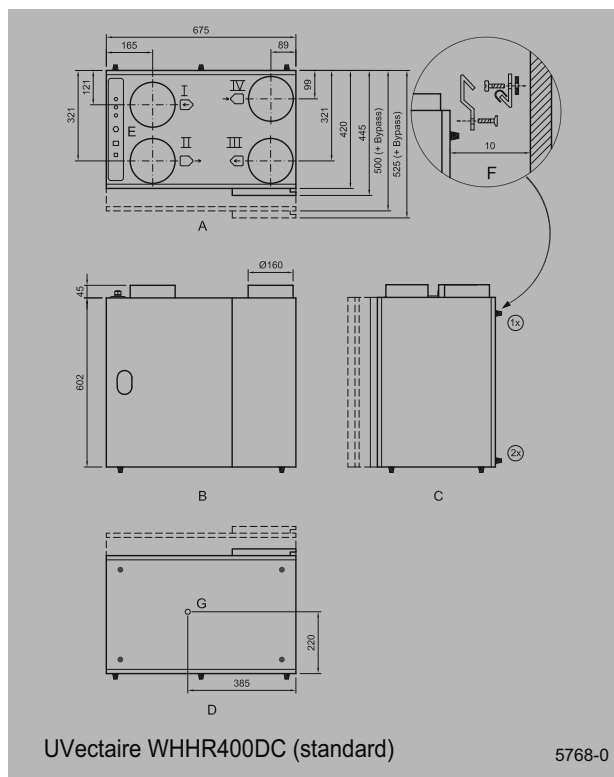
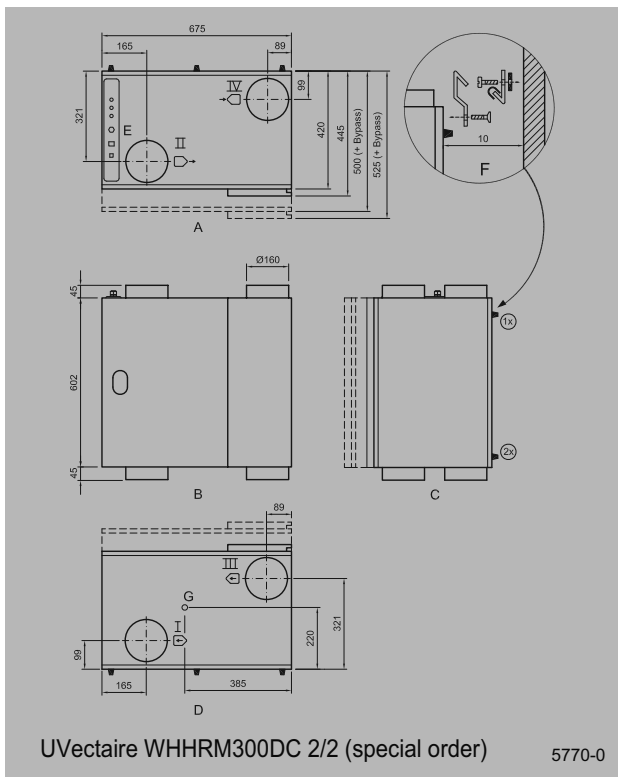

5.6.2 Connections Vectaire WHHR400DC

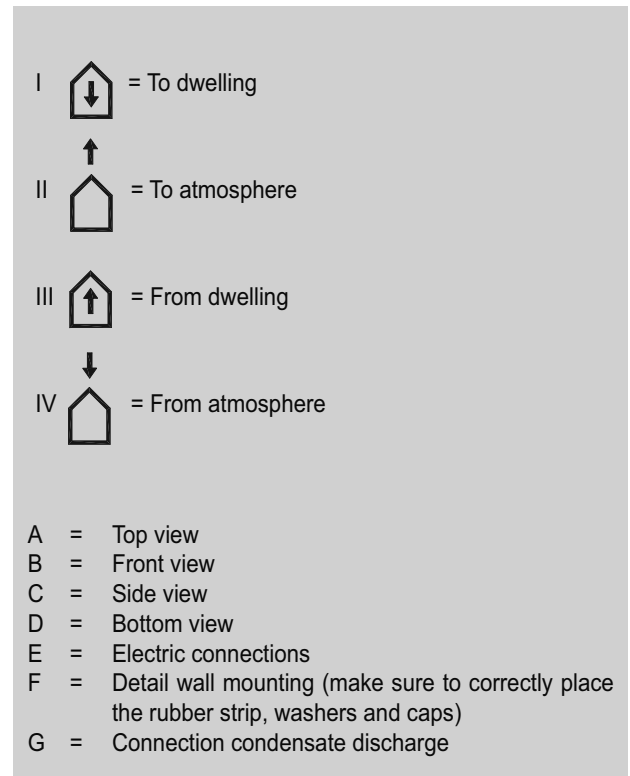
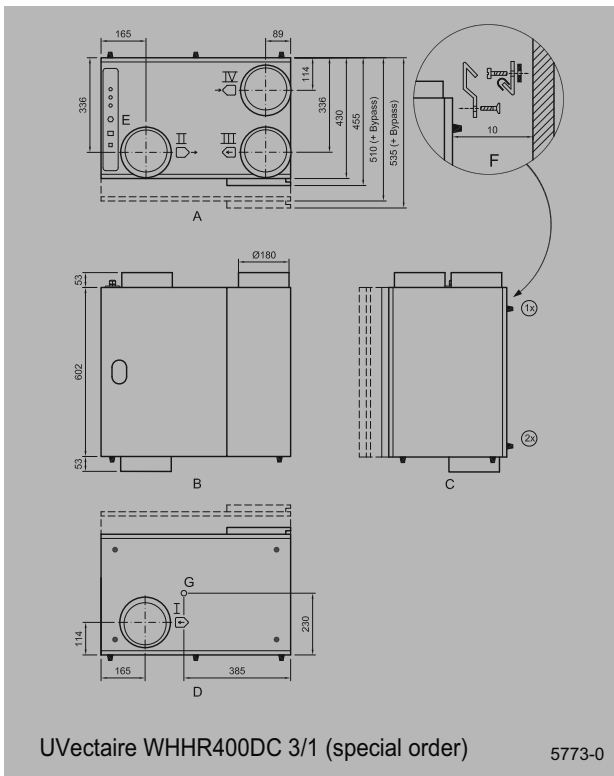
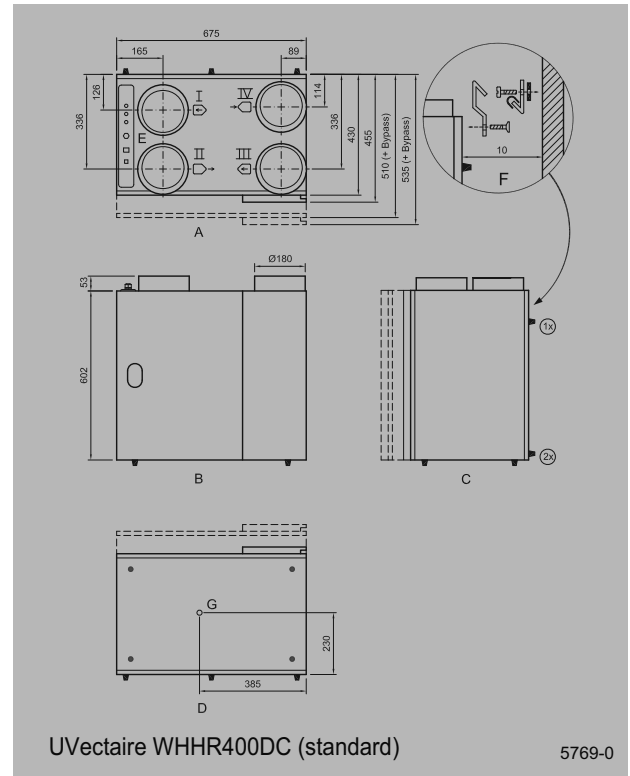
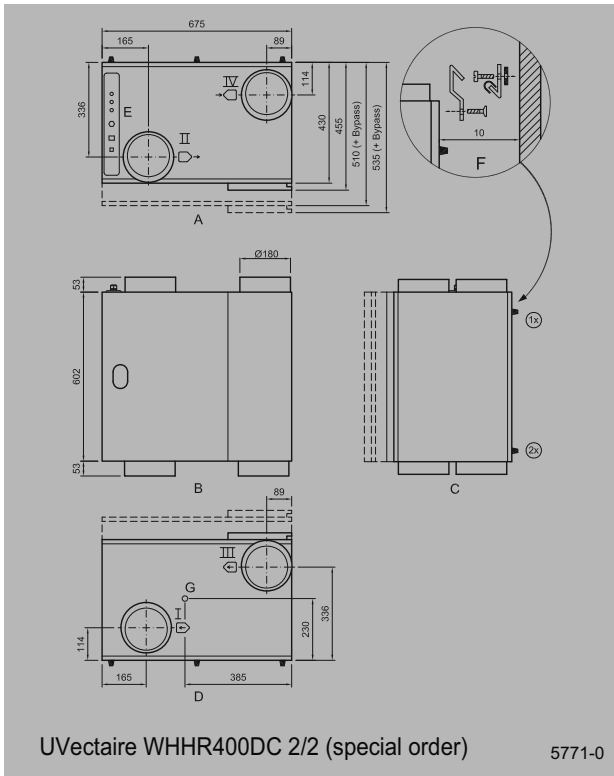

### 6.1 Switching the appliance on and off

There are two methods to switch the appliance on or off.

1. Through software; the appliance remains connected to the mains, when switching off by software only the fans are stopped.
2. Disconnecting from the mains.

#### Switching on

- Mains power: connect to the mains
- Through software; simultaneously press keys "OK" and "+" to switch on the appliance through software (Only possible after the appliance has been switched off through software.)



The first digit on the display indicates the position of the 3-way switch.

#### Switching off

- Through software; simultaneously press keys "OK" and "-" to switch off the appliance through software. The text OFF appears on the display.
- Mains power: disconnect from the mains.

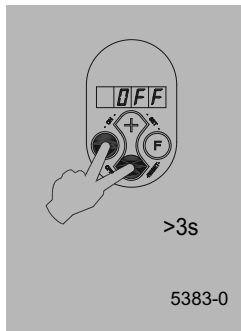

**NOTE!**

When working on the appliance, always switch off the appliance by first switching it off through software and subsequently disconnecting from the mains.

### 6.2 Setting the air quantity

The air quantity of the WHHRM300DC and WHHR400DC for settings 1, 2 and 3 have been set in the factory at 100, /150/200 and 225/300 m<sup>3</sup>/h. The performance of the appliance depends on the quality of the duct system as well as on the filter resistance.

**Important:**

Setting 1: must always be lower than setting 2.  
 Setting 2: must always be lower than setting 3;  
 Setting 3: adjustable between 50 and 300/400 m<sup>3</sup>/h;  
 If these conditions are not complied with, the air quantity of the higher setting will automatically be adjusted.

The air quantities can be modified as follows (as an example here the air quantity for setting 3 will be changed from 300 to 280 m<sup>3</sup>/h):

1. Press key "F" for 3 seconds to call up the settings menu.

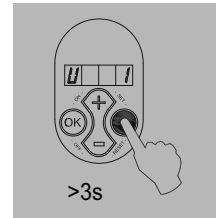

2. Use key "+" to select the desired parameter (U1 = setting 1: 1, U2 = setting 2: 2, U3 = setting 3; U4, U5 and U8 only apply when a bypass unit is used).

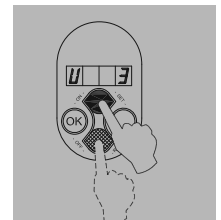

3. Press key "OK" for 1 second to read the selected parameter value.

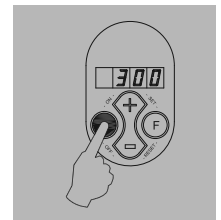

4. The keys "+" or "-" can be used to modify the selected parameter value.

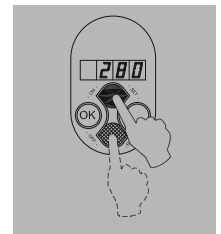

5. The modified setting can now be:  
**A saved and stored;**  
**B removed;**  
**C put back to factory setting.**

**A** Simultaneously press keys “F” and “+” (first F than +) to store the modified setting; the modified value will now blink 3x as confirmation. The display readout will remain at this modified value.

Press key “OK” to go back to the settings menu; if required, several settings can now be modified (see 2 to 5 inclusive). Now go to 6.

**B** Press key “OK” to go back to the settings menu without saving the modified setting; the previous setting will be maintained. If required, several settings can now be modified. Now go to 6.

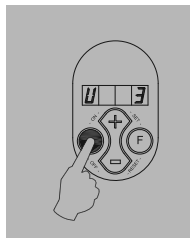
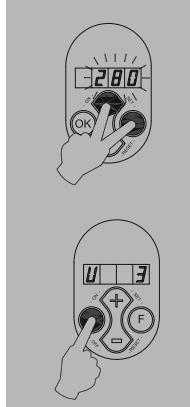

**C** Simultaneously press keys “F” and “-” to go back to the factory setting. The factory setting will blink 3x as confirmation. The modified setting is removed. The factory setting remains on the display. Press key “OK” to go back to the settings menu; if required, several settings can now be modified (see item 2 to 5 inclusive). Now go to 6.

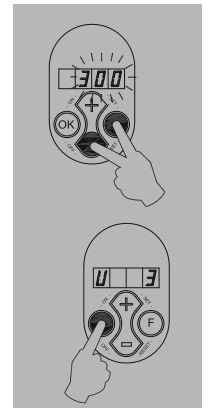

6. Press key “F” for 1 second to leave the settings menu.

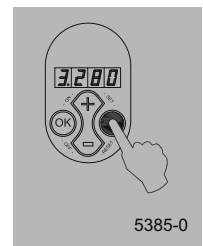

### 6.3 Other user settings

In addition to the air quantities per setting, the user can also adjust the following parameters.

- U4. Minimum atmospheric temperature bypass. This is the minimum atmospheric temperature at which the bypass opens, also when the indoor temperature satisfies the conditions.
- U5. Minimum indoor temperature for the bypass. This is the minimum indoor temperature at which the bypass opens, when the atmospheric temperature also satisfies the conditions.

U8 Not applicable

These setting possibilities are only relevant if the appliance is equipped with a bypass. These bypass settings are made in the same manner as described in section 6.2. Refer to the table in section 6.7.3 for the factory settings.

## 6.4 Installer settings

Various other settings of the control unit can also be modified. Because some settings have an influence on the correct operation of the appliance, these have been placed in a separate installer parameters set. Consequently, these parameters can only be modified by the installer. How to modify these is explained in section 6.7.2.

11. Fixed imbalance. This can be used to keep the pressure in the dwelling at a higher (+) or lower (-) level than the atmospheric pressure.

Positive imbalance (+): the output fan ventilates the set value in [m<sup>3</sup>/h] less than the input fan.

Negative imbalance (-): the input fan ventilates the set value in [m<sup>3</sup>/h] less than the output fan.

12. No contact step 11

This setting determines the ventilation position when no switch contact is connected to position 1; the appliance will start running at the ventilation position set here.

13. Not applicable.

14. Switch line 1 step.

Determines what position of the multiple switch matches line 1 on the control unit.

15. Switch line 2 step.

Determines what position of the multiple switch matches line 2 on the control unit.

16. Switch line 3 step.

Determines what position of the multiple switch matches line 3 on the control unit.

7. Imbalance permissible?

This determines whether for instance the frost protection may affect the imbalance.

- 18 Bypass mode.

There is a choice between 3 situations

Mode 0	The bypass valve is not operated
Mode 1 (standard setting)	The bypass valve - if installed - is opened when the temperature conditions are complied with
Mode 2	The inlet fan starts running at the lowest possible rpm if the temperature conditions are complied with

19. Hysteresis bypass.

Here can be entered how much the indoor temperature may drop before the bypass closes or the inlet fan starts running at the normal rpm.

110. Constant pressure switched off.

Here it can be set whether in all cases the fans are running at constant flow or that they start running at constant pressure when a certain resistance is exceeded.

111. Preheater or postheater.

This indicates whether a preheater or postheater is connected is.

Setting I11	Situation
0	No preheater or postheater
1	Preheater connected to basic pcb
2 & 3	Only use this setting for option pcb

112. Temperature preheater.

This sets the offset temperature preheater.

- 113 Filter message.

Sets whether the filter message is shown on the display and the LED of the 3-way switch.

- 114 Presence of option pcb.

This indicates whether an option pcb is installed.

- 115 Heat recovery configuration.

Option setting when heat recovery is used in combination with central heating; only heat recovery or the combination central heating + heat recovery.

Only heat recovery = 0; Central heating + heat recovery = 1

- 116 Fan setting for central heating + heat recovery

Fan(s) off for central heating + heat recovery (only applicable if I15 = 1).

Setting I16	Situation fan(s)
1	Output fan off
2	Input fan off
3	Both fans off

- 117 Repeat time in hours for switching off the fan(s) selected under I16 for central heating + heat recovery.

- 118 Maximum switch-off time in seconds for the fan(s) selected under I16 for central heating + heat recovery.

- 119 Minimum switch-off time in seconds for the fan(s) selected under I16 after switching on 230V for central heating + heat recovery.

Refer to the table in section 6.7.3 for the factory setting

### 6.5 Menu structure display

The menu structure is divided into a readout section and a settings section.

The number of visible parameters depends on the parameter set. The user has the parameter set "user"; a more compre-

hensive readout programme is available for the installer. It can be activated by simultaneously pressing keys "F" and "OK" for 3 seconds.

#### 6.5.1 Diagram menu structure

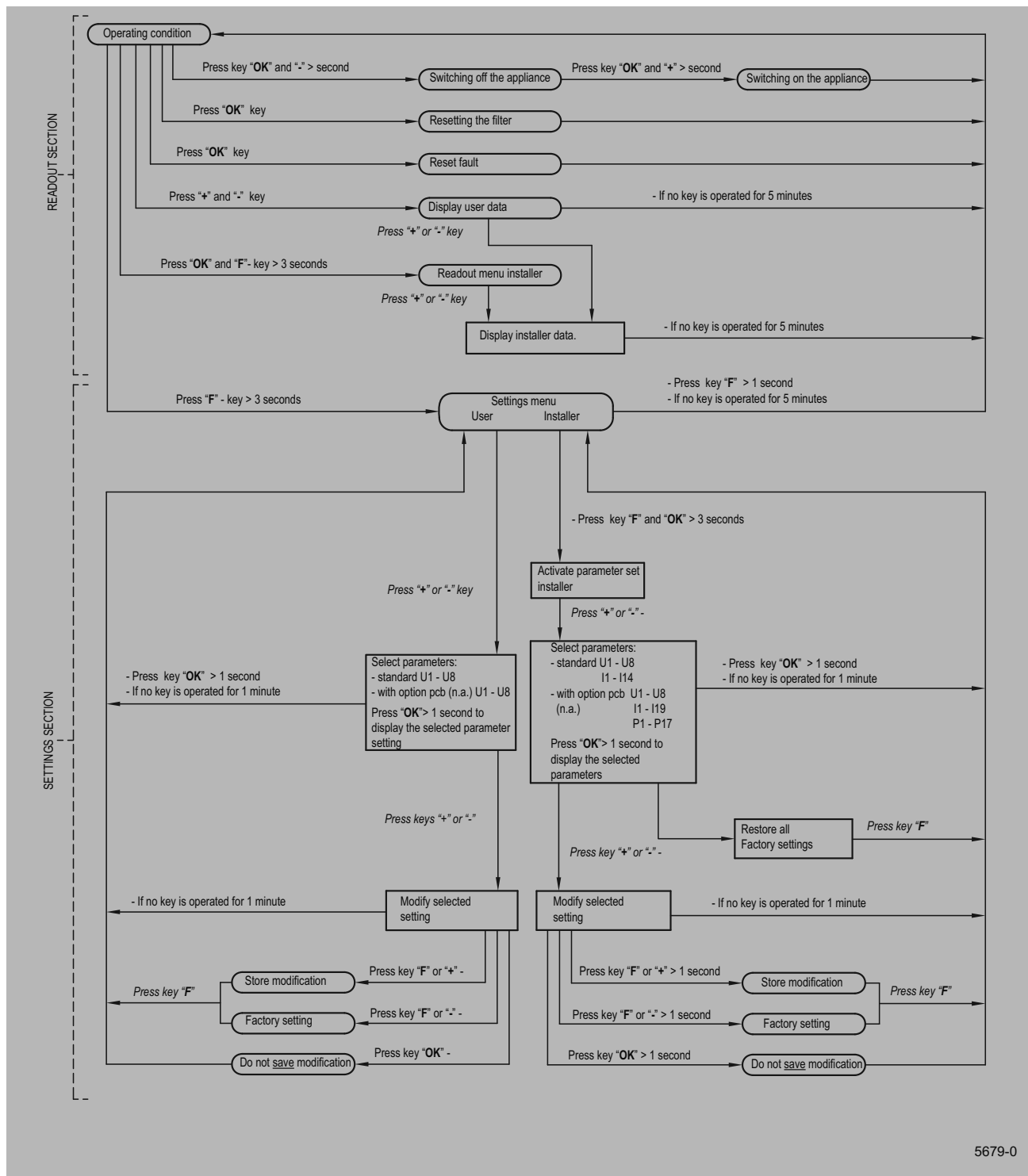

5679-0

### 6.6 Readout settings

As standard the current position of the multiple switch and the connected output volume are shown (Operational mode). On the left the position of the multiple switch (position 1, 2 or 3) is shown and to the right of the dot the volume of the output fan is shown.

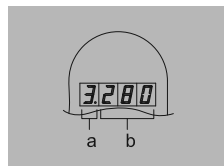

a = Setting the multiple switch  
b = Volume output fan

#### 6.6.1 Readout settings by the user

The user can read out other relevant data using keys "+" and "-" (step 0 to step 6). Step numbers are not shown on the display! See the table of section 6.6.2 for user readout; when no key is operated for 5 minutes, the display automatically returns to operational mode. Key "+" can be used to scroll through the menu; key "-" always takes you back to step 0. Modifying settings is not possible in this situation.

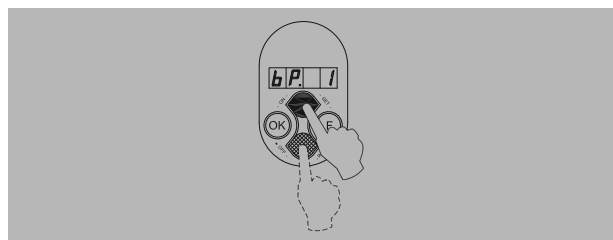

#### 6.6.2 Readout settings by the installer

A more comprehensive readout programme is available for the installer. Pressing keys "F" and "OK" for 3 seconds calls up all installer data. In this menu the values cannot be modified. Activating this menu always calls up step no. 7 (see table below); pressing key "+" calls up the installer and user data and pressing key "-" takes you back to step no. 1. After 5 minutes this menu automatically disappears and the display will show the operational situation again. In the event of an error, the error code appears on the display; see also chapter 7.

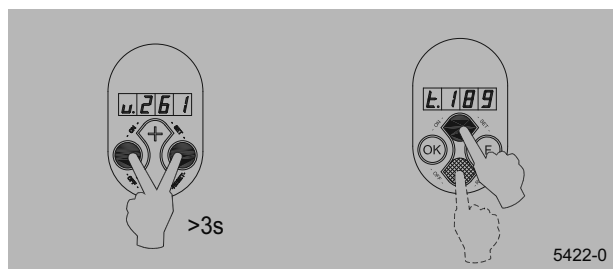

	Step number	Readout (example)	Description	Remark
User	No.1	2,200	Current position/outlet volume [m³/h]	
	No.2	C 0	Message code operating condition	C0 = No message C3 = The input fan runs in constant pressure mode C6 = The output fan runs in constant pressure mode C7 = Correction maximum air flow
	No.3	bP.1	Bypass status (only if mounted)	0 = bypass valve shut, 1 = bypass valve automatic 2 = input at minimum
	No.4	tP.9	Temperature from atmosphere [°C]	At negative temperature (below 0°C) then readout tP.9.
	No.5	tS.21	Temperature from indoors [°C]	
	No.6	In.0	n.a.	
installer	No.7	u.156	Current input volume [m³/h]	
	No.8	v.156	Current output volume [m³/h]	
	No.9	t.180	Current pressure input duct [Pa]	
	No.10	A.180	Current pressure output duct [Pa]	
	No.11	u0.0	Status frost protection	0 = none, 1 - 4 = imbalance, 5 = input fan off
	No.12	St.9	Temperature to atmosphere [°C] (Sensor not connected as standard)	If not connected St.75
	No.13	Pt.18	Temperature to indoors [°C] (Sensor not connected as standard)	If not connected Pt.75

### 6.7 Modifying settings

A number of settings can be modified by both user and installer to adapt the appliance to the specific situation.

#### 6.7.1 Modifying settings by the user

The user can modify a limited number of settings, that is U1 to U8 inc. (see table section 6.7.3); how to modify these settings

is described in detail in section 6.2 and is also shown in the diagram menu structure of section 6.5.

#### 6.7.2 Modifying settings by the installer

The installer can modify more settings. When parameters are set incorrectly, the appliance will no longer perform up to standard, so make sure no parameters are modified incorrectly. Also refer to the diagram menu structure section 6.5. The following actions are required to modify the settings from operational mode:

(By way of example parameter 18 (bypass mode) is changed from 1 to 2.)

- 1 Press key "F" for 3 seconds to activate the settings menu.

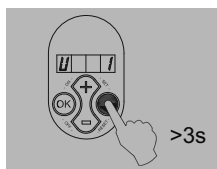

- 2 Press key "F" and key "OK" for 3 seconds to activate the comprehensive installer parameters set.

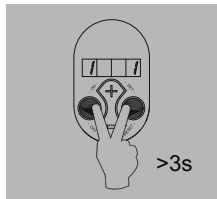

- 3 The desired parameter can be found with the aid of keys "+" and "-". (See table section 6.7.3)

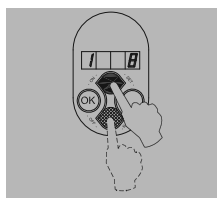

- 4 Pressing key "OK" calls up this setting.

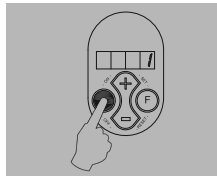

- 5 Use keys "+" and "-" to modify the value.

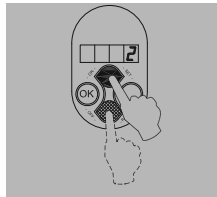

- 6 The modified setting can now:
  - A be saved and stored
  - B be removed;
  - C be restored to factory setting.

**A** Simultaneously press keys "F" and "+" (first press "F" and " then "+" ) to store the modified setting; this value now blinks 3 times to confirm that it has been stored; the value remains on the display. Press key "OK" to return to the settings menu; if required, other settings can now be modified (step 2 - step 5). Continue with step 7.

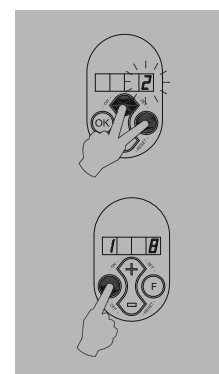

**B** Press key "OK" to go back to the settings menu without saving the modified setting; the previous setting will be maintained. Continue with step 7.

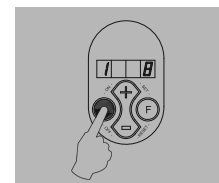

**C** Simultaneously press keys "F" and "-" (first "F" and then "-" ) to go back to the factory setting. The factory setting will blink 3 times and remain at that value. The modified setting has now been removed. Press key "OK" to return to the settings menu. Continue with step 7.

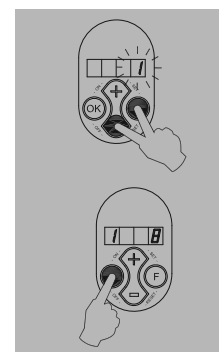

- 7 Press key "F" for 1 second to leave the settings menu.



5423-0

### 6.7.3 Adjustable settings table

The user-adjustable parameters are indicated with "U"; the installer-adjustable parameters are indicated with "I" (basic pcb) or "P"(option pcb).

	Adjustable parameter	Description	Setting range	Factory setting	
User	U 1	Volume step 1	50..(max-10)	100	
	U 2	Volume step 2	50..(max-5)	M300DC 150 400DC 200	
	U 3	Volume step 3	50..300 (M300DC) 50..400 (400DC)	225 M300DC 300 400DC	
	U 4	Minimum atmospheric temperature bypass	5 .. 20	10	
	U 5	Minimum indoor temperature bypass	18 .. 30	22	
	U 8	Not applicable	0.1	0 (off)	
	Installer	I 1	Fixed imbalance	-100..+100	0
		I 2	No contact step	0,1,2,3	1
I 3		Not applicable	2.3	2	
I 4		Switch line 1 step	0,1,2,3	1	
I 5		Switch line 2 step	0,1,2,3	2	
I 6		Switch line 3 step	0,1,2,3	3	
I 7		Imbalance permissible	0.1	1 (Yes)	
I 8		Bypass mode	0,1,2	1	
I 9		Hysteresis bypass	0 .. 5	2	
I10		Constant pressure switched off	0.1	0 (no)	
I11		Preheater or postheater	0, 1, 2, 3	0	
I12		Offset temperature preheater	-30 .. + 30	0.5	
I13		Filter message on/off	1.0	1 (on)	
I14		Option pcb present	1.0	0 (no)	
I15		Heat recovery configuration	0.1	0 (heat recovery)	
I16		Fan off	1,2,3	1 (Output fan)	
I17		Repeat time	1 .. 24	24 (hours)	
I18		Minimum switch-off time fan(s)	1 .. 240	60 (seconds)	
I19		Minimum switch-off time fan(s) after switching on 230V.	1 .. 240	1 (second)	

For a description of these settings refer to section 6.2 and 6.3 for U1 - U8 and section 6.4 for I1 - I19.

The description of parameters P1 - P17 that may be displayed are included in the installation instructions that come with the option pcb.

7.1 Trouble shooting

If the control system detects an error, this is shown on the display by means of a number, preceded by a letter **F** (Failure). If a 3-way switch with filter indication is mounted, the LED on the 3-way switch will also start blinking.

The examples shown here is the error **F9**.; this means something is wrong with the wiring to the atmospheric temperature sensor or with the sensor itself.

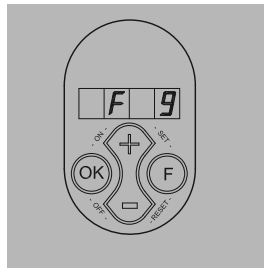

The appliance remains in this error mode until the problem in question has been solved. Then the appliance will reset itself (auto reset) and the display will once more show operational mode.

The table to section 7.3 gives an overview of the errors, possible causes and the actions to be undertaken.

7.2 Filter indication

If the display shows the message "**FIL**" then this means the filters have to be cleaned. If a multiple switch with filter indication has been installed, then simultaneously with this message on the display, the LED on the switch will light up.

After the filters have been cleaned or replaced, the key "**OK**" must be pressed for 1 second to reset the filter indication. The text "**FIL**" will blink for a moment and then the display will return to operational mode.

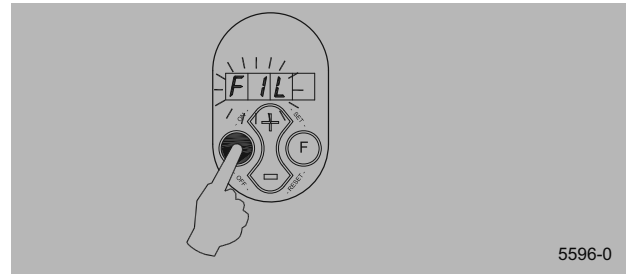
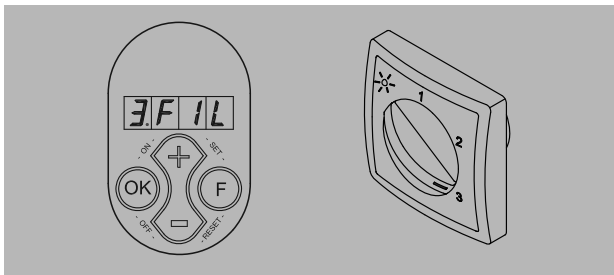

5596-0

7.3 Display codes

Table fault codes

Fault code	Cause	Action user	Action installer
<b>F2</b>	The inlet fan has stopped.	• Contact the installer.	• Replace the inlet fan.
<b>F5</b>	The outlet fan has stopped.	• Contact the installer.	• Replace the outlet fan.
<b>F9</b>	The temperature sensor that measures the temperature of the input air is defective. The appliance operates as expected, but the bypass is out of operation.	• Contact the installer.	• Check the wiring from the sensor to the basic pcb. • Check the sensor connection. Replace the sensor.
<b>F10</b>	The temperature sensor that measures the temperature of the output air is defective. The appliance operates as expected, but the bypass is out of operation.	• Contact the installer.	• Check the wiring from the sensor to the basic pcb. • Check the sensor connection. Replace the sensor.

Note!

If setting 2 does not work with a mechanical rpm control device such as a multiple switch, the RJ connector has been connected the wrong way round. Cut off one of the RJ connectors

to the rpm control and mount a new connector the other way round .

8.1 User maintenance

User maintenance is limited to periodically cleaning or replacing the filters. The filter only has to be cleaned when indicated on the display (it shows the text "FIL") or, if a multiple switch with filter indication is mounted, when the red LED at the switch lights up. The filters should be replaced every year. Do not use the appliance without filters.

- Put the 3-way switch at setting 1 to let the appliance's fans run at low speed. Open the filter door.

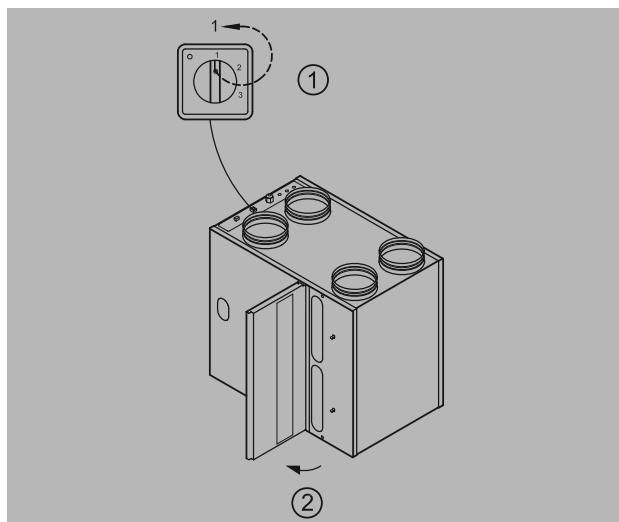

- Remove the filters. Remember in what way the filters are taken out.

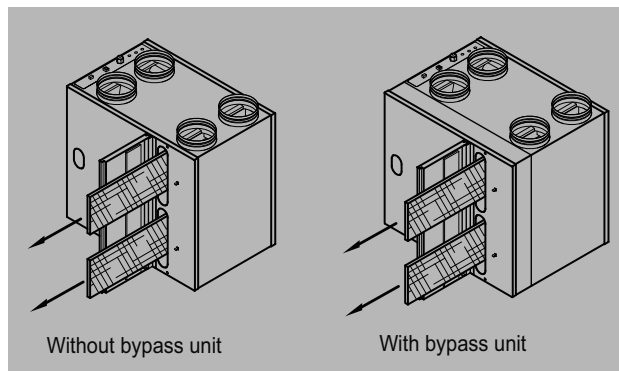

- Use a vacuum cleaner to clean the filters.

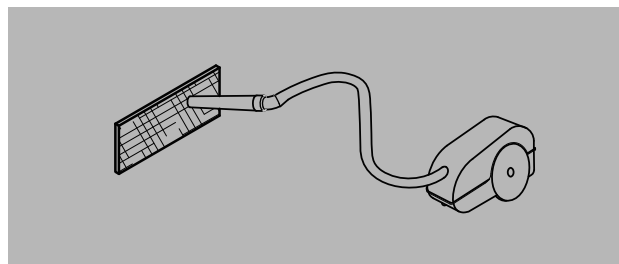

- Place the filters back the same way as they were taken out.

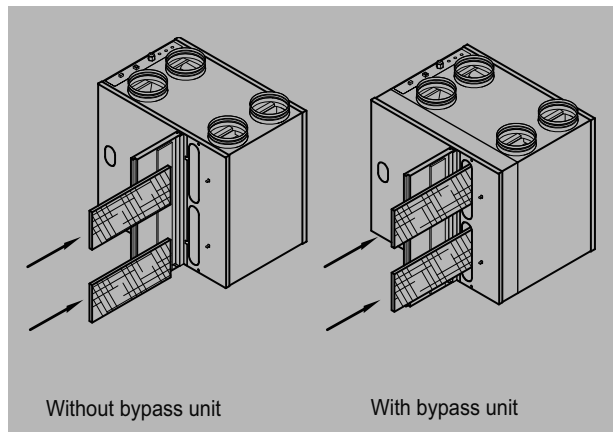

- Close the filter door. After cleaning the filter or a fitting a new filter, the filter indication must be reset by pressing key "OK" for 1 second. The display will blink for a moment to confirm that the filter has been reset. The appliance will return to operational mode. Put the 3-way switch back to the original setting.

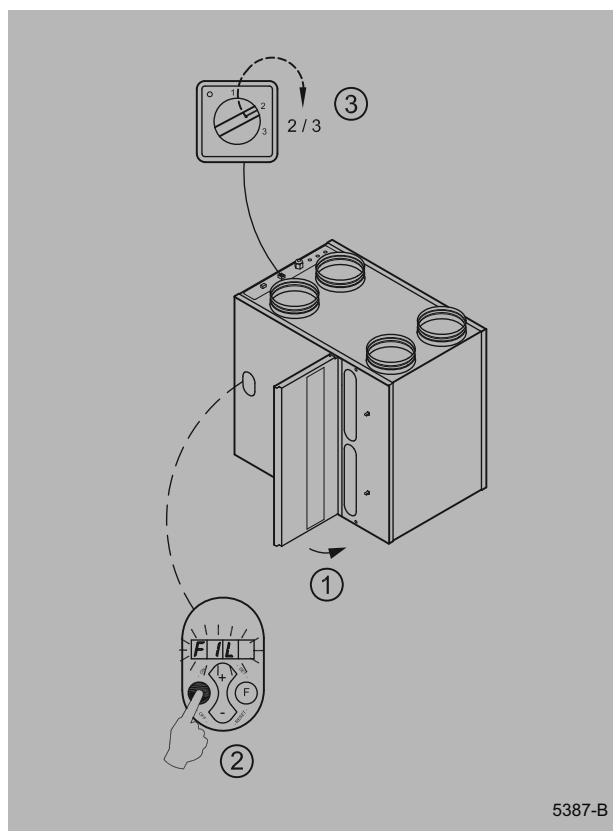

5387-B

8.2 Installer maintenance

Installer maintenance includes cleaning the heat exchanger and fans. Dependent on the conditions, this must be done about once every three years.

- 1 Switch off the appliance on the control panel (simultaneously press keys "OK" and "-" and "-" for 3 seconds) and switch off the power supply. Open the filter door.

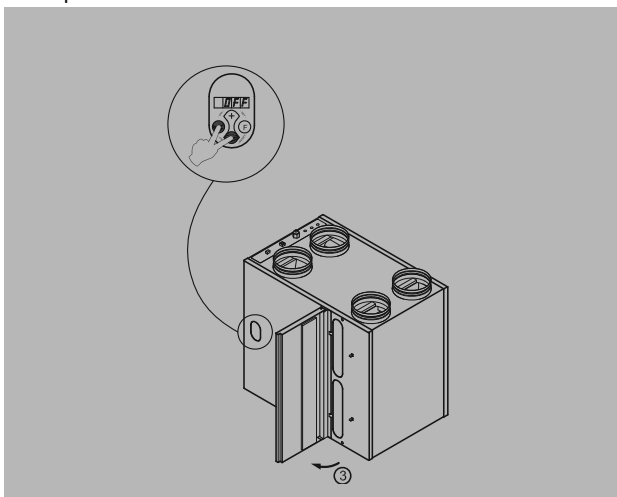

- 2 Remove the filters.

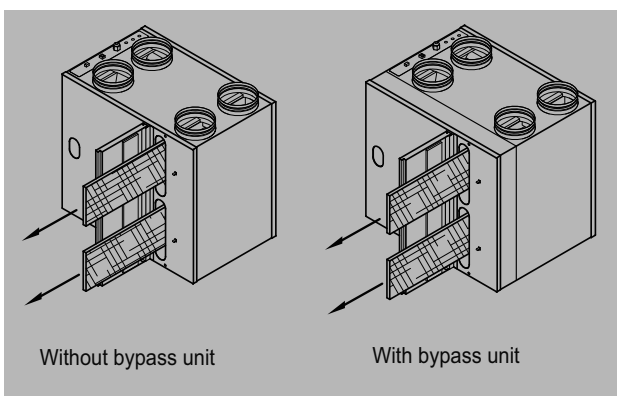

- 3 Remove the front cover

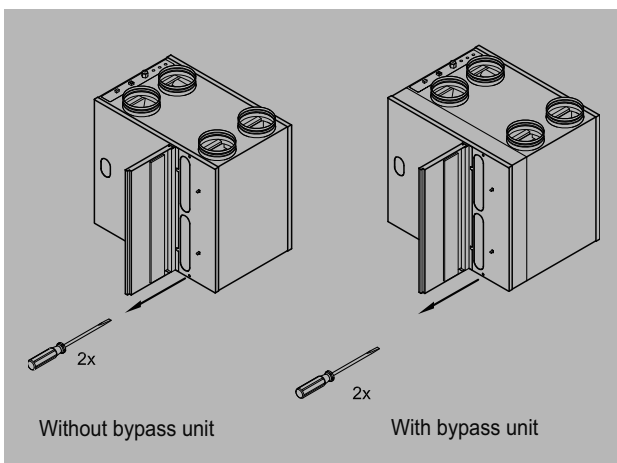

- 4 If the appliance is equipped with the optional bypass unit, it must now be removed. First remove the display (see item 7 for appliance without bypass unit) and unscrew the four hexagon socket bolts M6 x 16; pull the connectors and remove the bypass unit from the appliance.

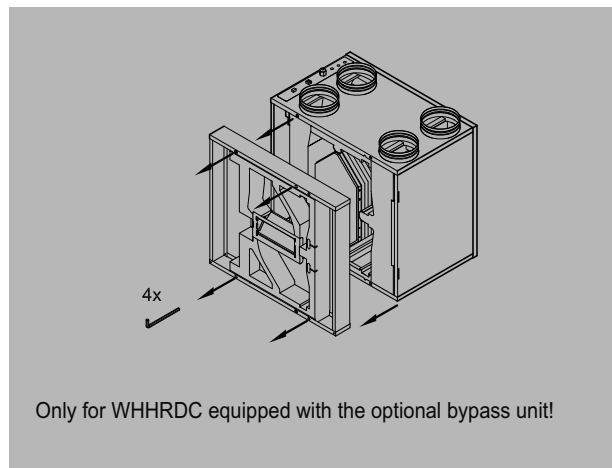

- 5 Remove the heat exchanger. Be careful not to damage the foam parts in the appliance.

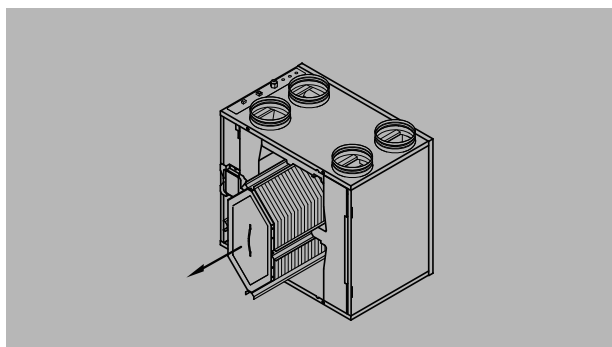

- 6 Clean the heat exchanger using hot water (55°C max.) and a regular detergent. Rinse the exchanger with hot water. If the appliance came ex-factory with a bypass, then first remove the valve control device from the sliding grate.

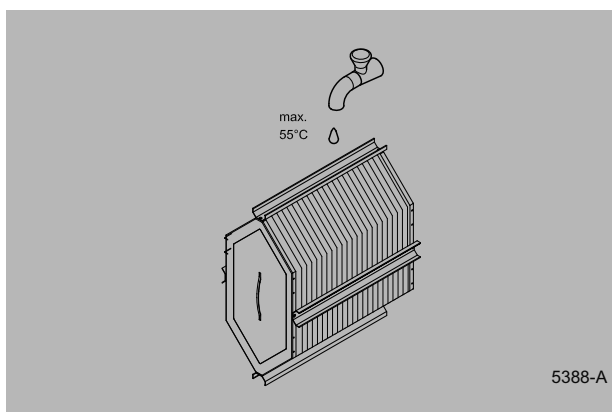

7 Remove the control panel.

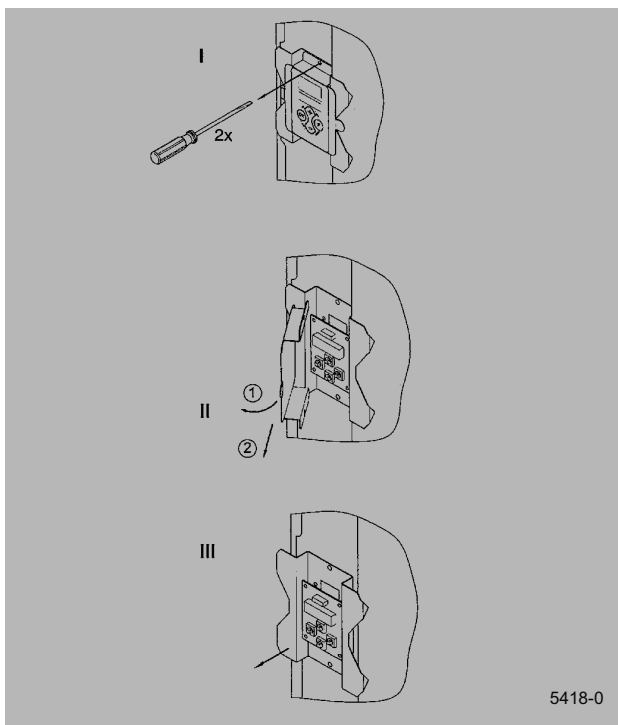

8 Pull all connectors from the basic pcb. Take the earth wire from the housing.

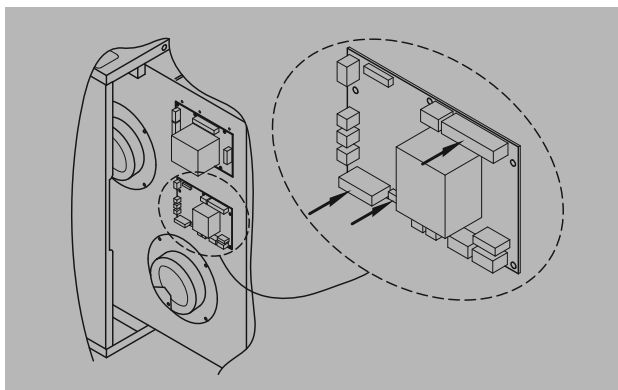

9 Remove the fan unit.

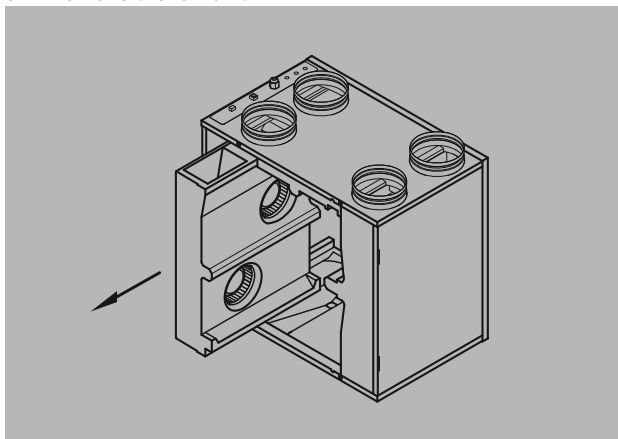

10 Remove the spiral casing.

11 Clean the fan with a soft brush. Make sure the balancing weights do not shift.

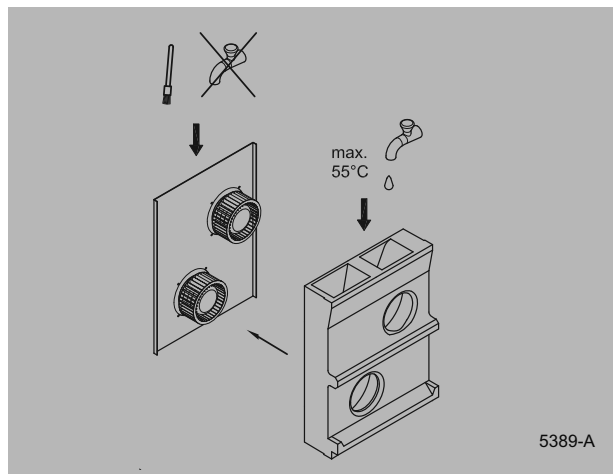

12 Place the spiral casing back on the fan unit.

13 Place the fan unit back in the appliance.

14 Place the earth wire back and replace the connectors that were removed.

15 Replace the control panel.

16 Place the heat exchanger back into the appliance.

17 Replace the bypass unit if applicable and then the front cover.

18 Place the filters back into the appliance with the clean side facing the exchanger.

19 Close the filter door.

20 Switch on the power supply.

21 Switch on the appliance on the control panel (simultaneously press keys "OK" and "+" for 3 seconds).

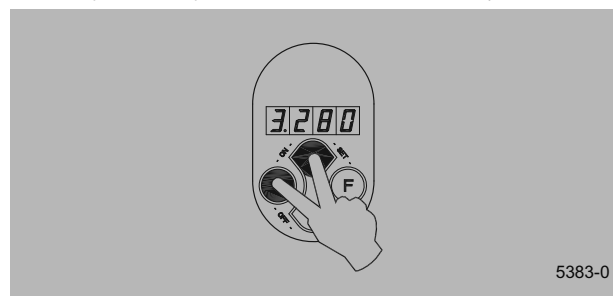

22 After cleaning the filter or a placing a new filter, the filter indication must be reset by pressing key "OK" for one second

9.1 Basic diagram without bypass

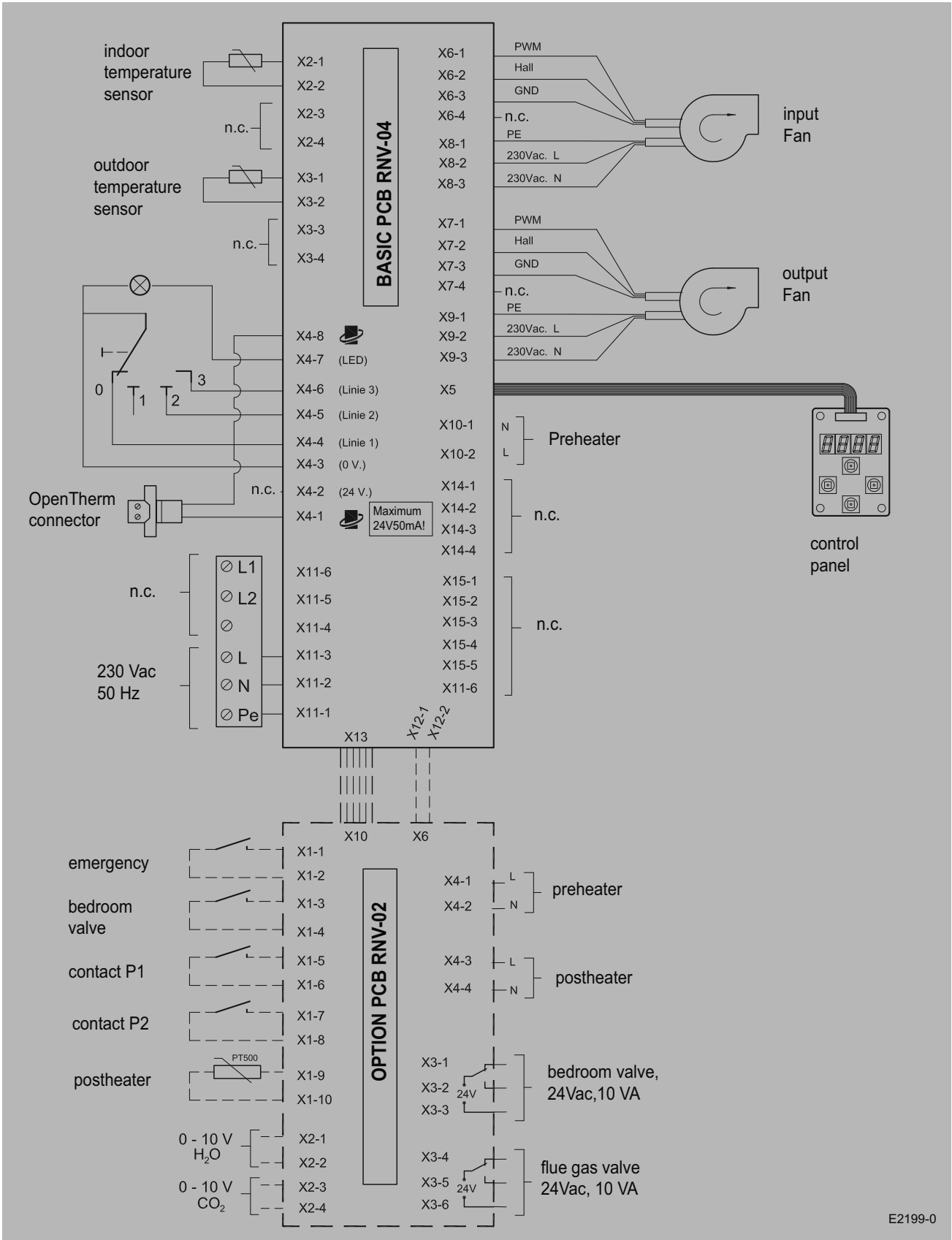

E2199-0

9.2 Basic diagram with bypass

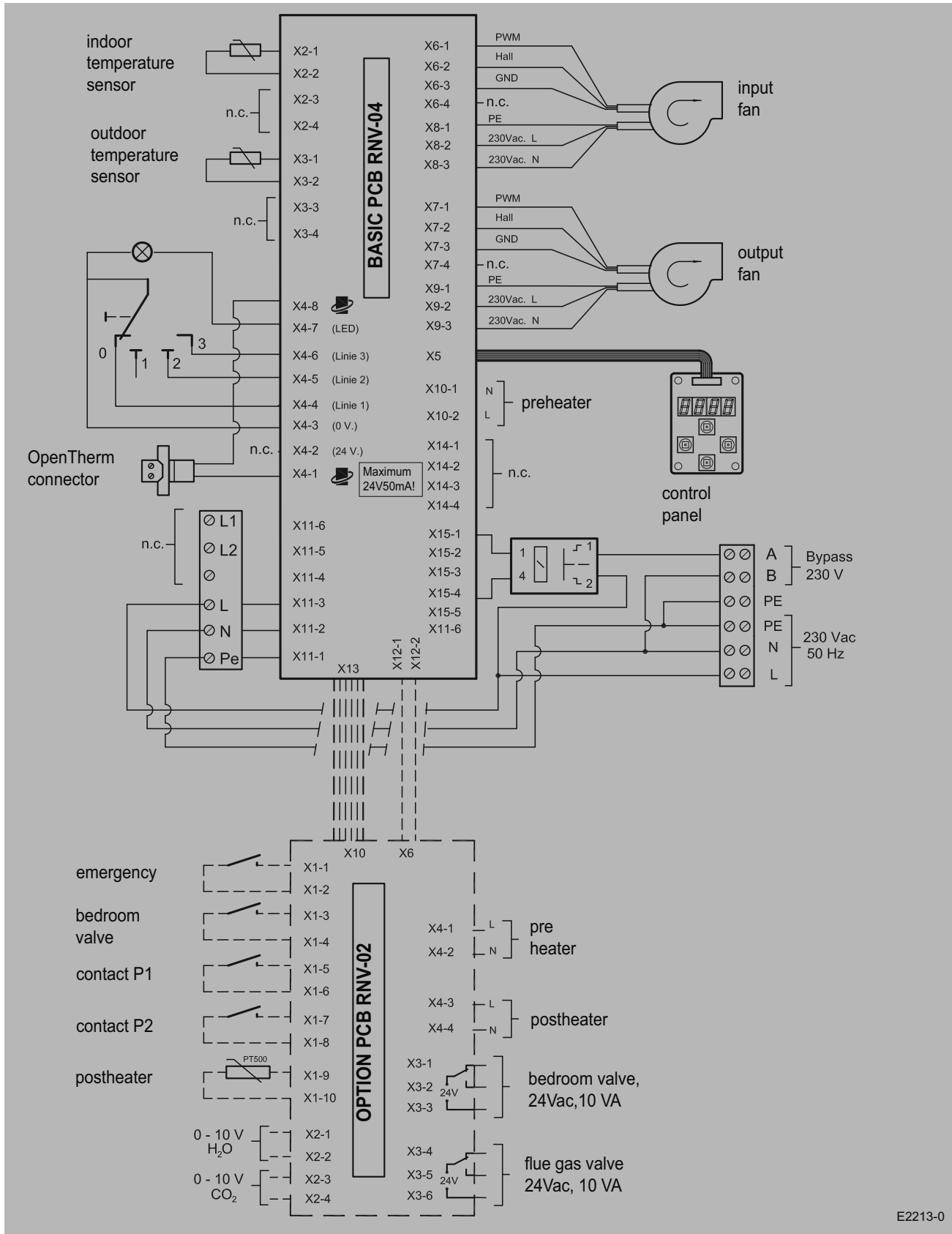

E2213-0

9.3 Wiring diagram without bypass

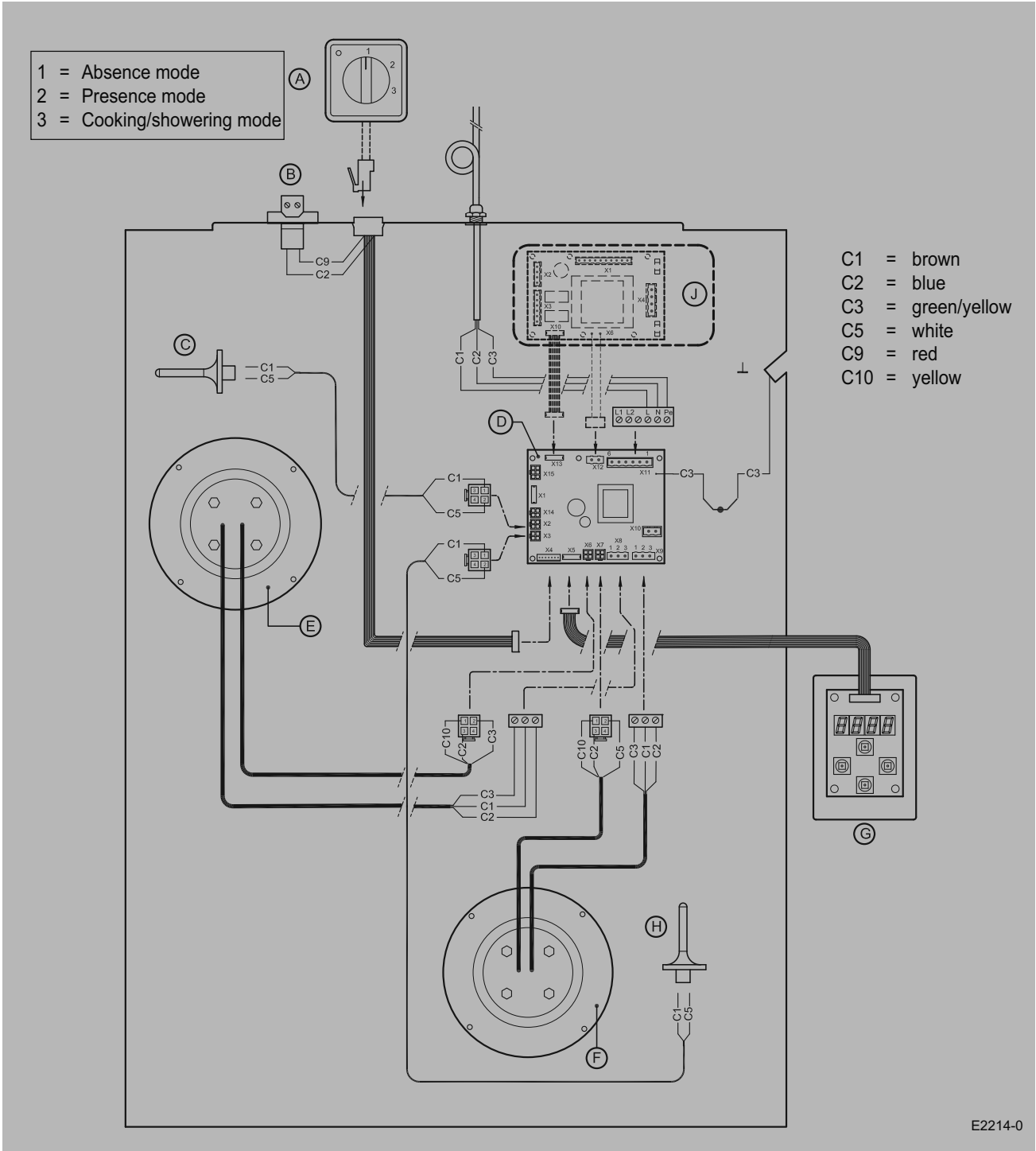

a = 3-way switch

B = OpenTherm connector

C = Interior temperature sensor

D = Basic pcb

E = Input fan

F = Output fan

G = Control panel

H = Atmospheric temperature sensor

J = Option pcb (not mounted as standard)

9.4 Wiring diagram with bypass

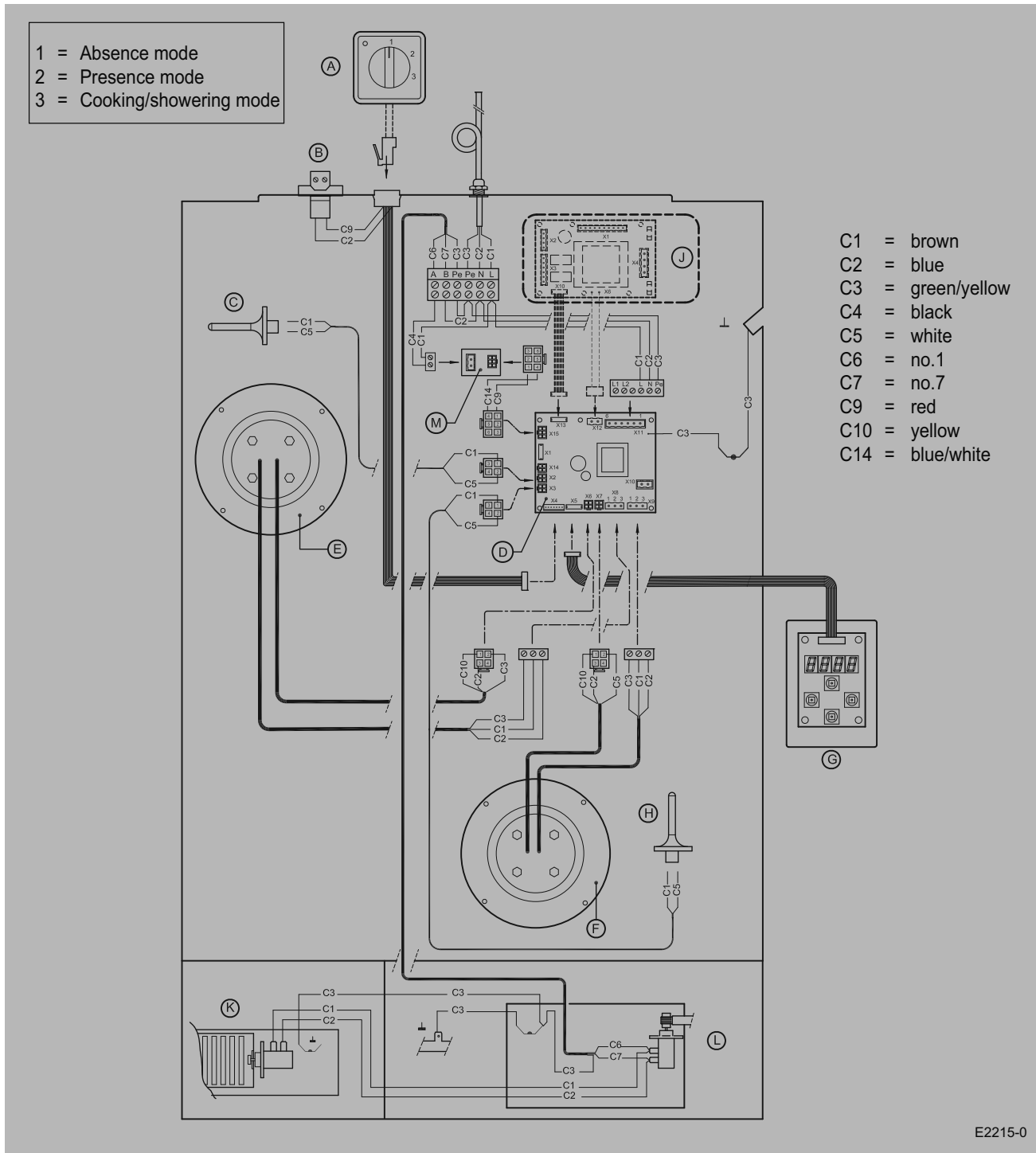

- |   |  |
|---|--|
| <p>A = 3-way switch<br/>             B = OpenTherm connector<br/>             C = Interior temperature sensor<br/>             D = Basic pcb<br/>             E = Input fan<br/>             F = Output fan</p> | <p>G = Control panel<br/>             H = Atmospheric temperature sensor<br/>             J = Option pcb (not mounted as standard)<br/>             K = Valve control device sliding grate (only for bypass ex factory)<br/>             L = Valve control device bypass valve (only if bypass is mounted)<br/>             M = Bypass pcb (not mounted as standard)</p> |
|---|--|

9.5 Wiring diagram connection preheater to WHHRDC without option pcb

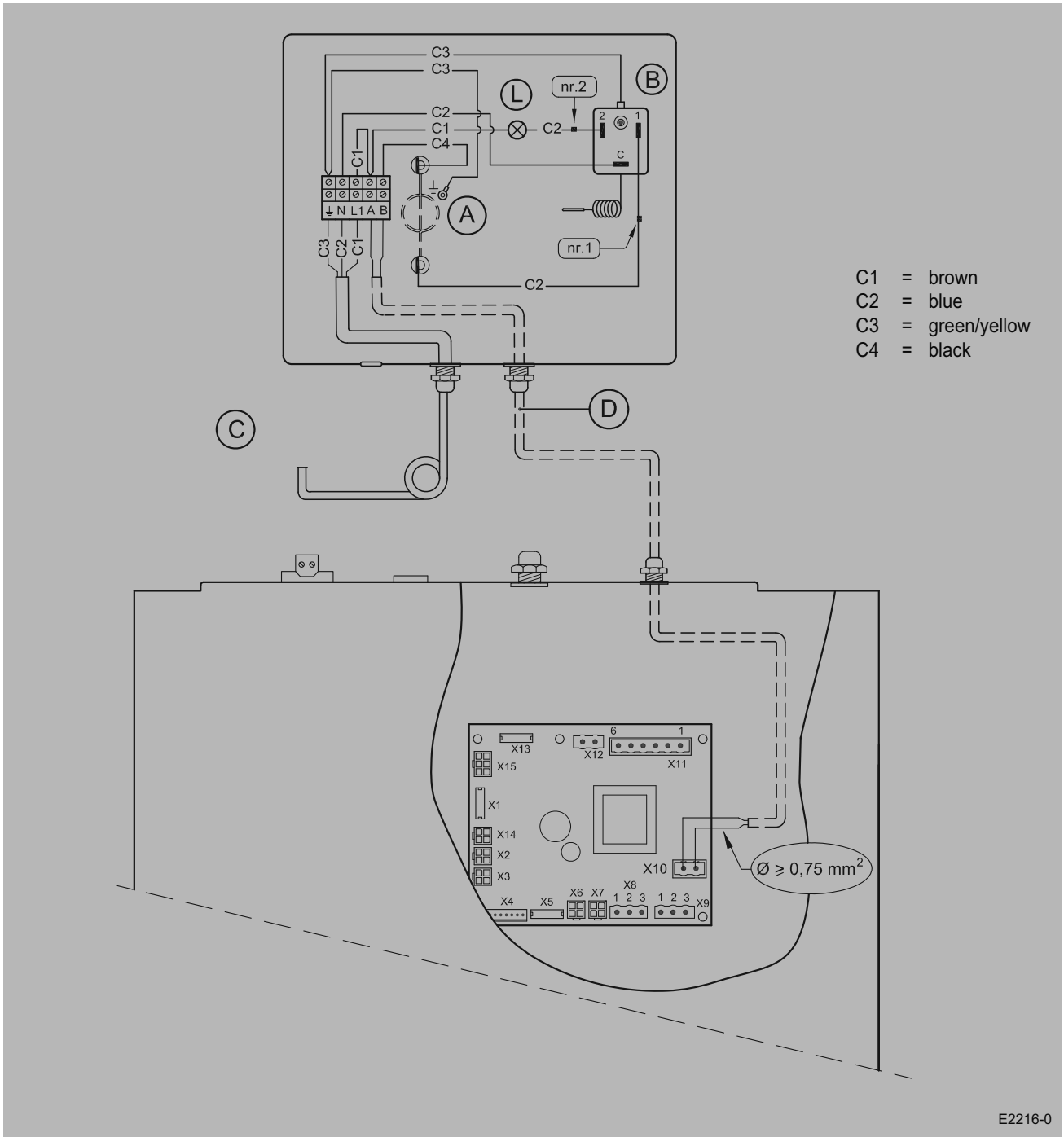

- A = Heating coil
- B = Maximum safety with manual reset
- C = Connection to mains
- D = Cable to be connected by installer
- L = LED maximum safety; lights up when activated

**Note!**  
 Setting I11 must be set at "1" when connecting the preheater to the basic pcb!  
 See section 6.4

**10.1 Exploded view WHHRM300DC & 400DC**

When ordering parts, in addition to the product code number (see exploded view), please state the type of the heat recovery appliance, the serial number, the year of production and the name of the part:

**N. B.:**  
Appliance type, serial number and year of production are stated on the identification plate on top of the appliance.

Example	
Appliance type	: Vectaire WHHRM300DC
Serial number	: 290002081801
Year of construction	: 2008
Part	: Fan
Product code	: 531496
Quantity	: 1Ve

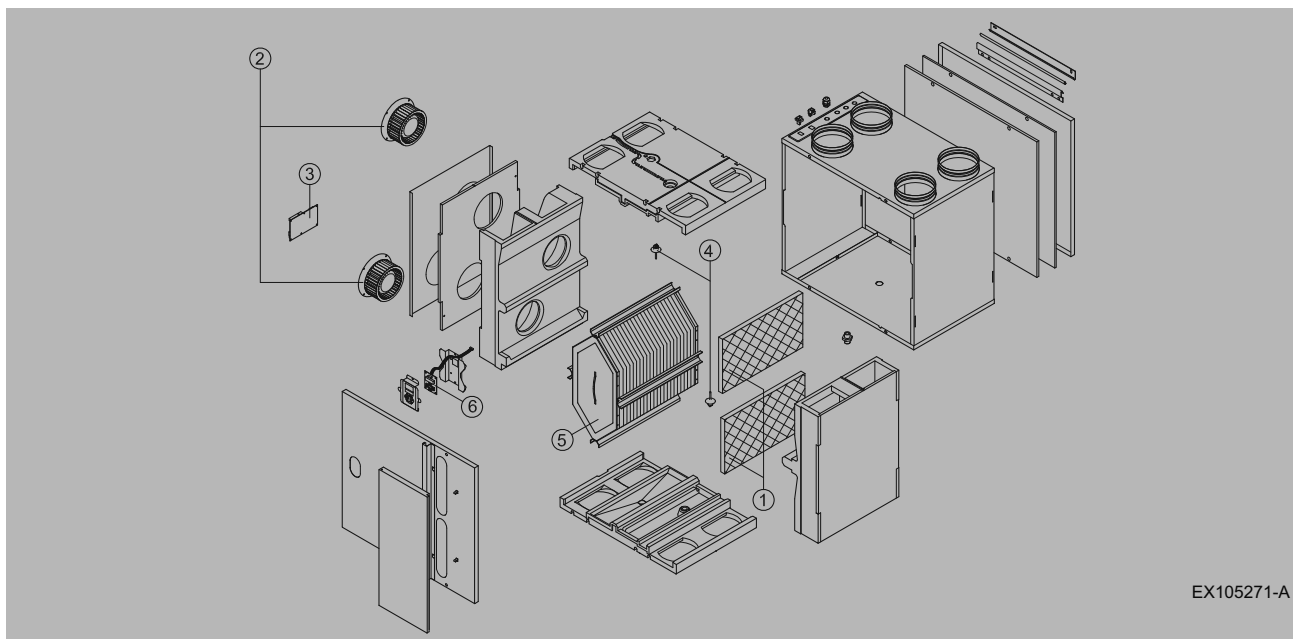

**10.2 Spare parts WHHRM300DC & 400DC**

No.	Spare parts	Product code
1	Filter kit (standard version)	531101
	Filter kit (version with bypass)	531286
2	Fan Medio	531496
	Fan Grande	531565
3	Basic pcb Medio	531566
	Basic pcb Grande	531567
4	Temperature sensor	531451
5	Heat exchanger or	531107
	Heat exchanger with grid (only for factory-fitted bypass)	531453
6	Control panel with display	531452

Vectaire Ltd's policy is one of constant improvement and development. Therefore the right is reserved to change specifications without prior notice.



## **DECLARATION OF CONFORMITY**

*The heat recovery appliances type*

**Vectaire WHHRM300DC and WHHR400DC**

*bear the CE label*

*and satisfy the machine directive 89/392/EEC, the low voltage directive 73/23/EEC,*

*the materials directive ROHS 2002/95/EC and the EMC directive 89/336/EEC.*

*These heat recovery appliances are manufactured from high-quality materials and that continuous quality control ensures that they comply with the above directives.*